



INTRODUCTION.

The AP Racing range of Ventilated and Solid Brake Discs have been developed with the benefit of unparalleled experience in brake technology, to meet the severe demands encountered under Race, Rally and Road conditions.

RACE:

Our extensive range includes discs to suit all of the most demanding series in the world. Teams competing in F1, F3, WRC, GT and Sports Prototypes, Nascar and Touring Car Championships use AP Racing discs.

ROAD:

As well as our successes on the circuits and stages of the world, AP Racing develop Disc Braking systems for many leading volume and specialist High Performance Vehicle Manufacturers including Aston Martin, Bentley, Caterham, HSV, Lotus, Noble and TVR etc...

RESEARCH AND DEVELOPMENT.

Over the last three years AP Racing has placed increased emphasis on advanced research and simulation to complement the existing technology, test and manufacturing processes of our Competition and Road Discs. Product improvement is continuous using feedback from our new state of the art dynamometer and track testing AP Racing are able to offer brake discs with optimum performance and cooling characteristics for any applications.

DESIGN.

AP Racing share innovations in the R&D processes between Race and Road projects, the basic function is the same for both although each has different service requirements.

- **Race Discs** are submitted to high braking and thermal loads. These loads are repeated frequently over many laps or stages. The service life is short and noise and comfort are not really an issue. Race Discs normally employ a separate disc and bell assembly which are generally available in two types:

- Light Duty - 1 piece bolted assemblies.
 - Heavy Duty - 2 piece floating assemblies.
- A given disc has to fit many different customer cars, so they require custom mounting bells.

- **Road Discs** however have relatively low and infrequent loads, although mass increases compared to race cars which

generates high braking torques. Road Discs have comfort and long service life requirements. Costs of each item also have to remain low for the OEM and the end user when replacement time arrives. Of course there are exceptions, Big Brake upgrades kits can be fitted, these kits are closer to race disc's than road. For road cars however, many applications use 1 piece disc and bell assemblies, this is due to high volume production on one type of upright. High performance vehicles use 2 piece bolted assemblies, enabling to fit a heavy duty race disc.

- Light Duty - 1 piece disc and bell assembly.
- Heavy Duty - 2 piece bolted assemblies.

DEVELOPMENT TOOLS.

AP Racing is now equipped with state of the art design tools which have enabled us to study disc performance to a level not hitherto possible.

- FEA: CFD AND THERMAL STRESS ANALYSIS.

Thermal simulation enables assessment of brake disc cooling without having to build costly prototypes.

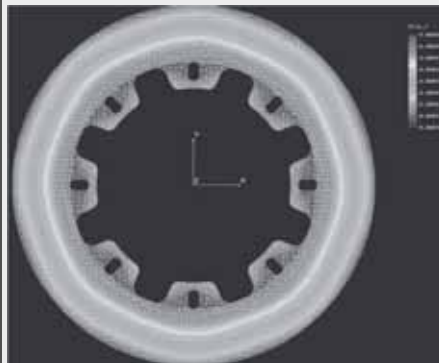

AP Racing has reached a high degree of confidence using these methods and has adopted FEA as the base of our design process, this enables AP Racing to tailor disc design to a given application.

- DYNAMOMETER TESTING.

Not everything can be modelled yet, so validation testing is essential. Our proven dynamometer, has been supplemented by a second, more powerful machine equipped with state of the art features. Two fully operational dyno's to give us even more significant test capabilities



and help us demonstrate that AP Racing Brake Discs are the best. Fig 1, shows 2

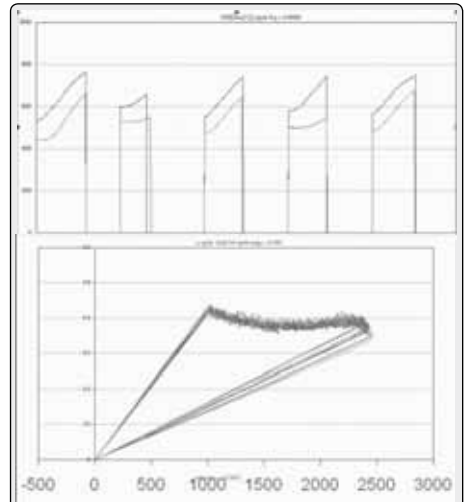

Fig 1.

Dynamometer plots which are examples of the data we can extract: Temperature and Friction Co-efficient comparison.

NUMERICAL SIMULATION.

AP Racing has developed unique thermal simulation software, in order to predict overall brake system temperatures on a real life cycle.

This simulation is particularly useful for selection of brake specifications, and wear predictions for endurance races. It is able to calculate bulk temperatures and compare different brake system solutions for various vehicles and race tracks.

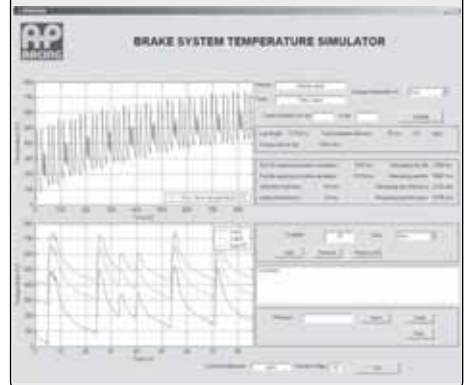

R&D EXAMPLES

Three examples of how this simulation software has already benefited the AP Racing Disc range.

- 'J HOOK' Face Design

One of the most instantly recognisable features of our new generation of brake discs is the 'J Hook' groove pattern. Grooves have to perform several tasks:

- Face Cleaning.
- Increase abrasive friction.
- Cover whole braking face.
- Avoid creating stress raisers.



Traditional groove designs achieve this with straight or curved groove running from the braking

face inside diameter to its outside diameter. This is very effective, however when the disc face heats up the groove acts a like a cold spot. This creates a thermal distortion on the braking face, which reduces braking efficiency. The 'J hook' design provides for a constant path of evenly distorted material on the braking face, the pad never loses contact with the braking face, improving the friction characteristics and brake performance.



- Wide Disc Technology.

In order for a disc to perform consistently the disc

must efficiently transfer heat to the surrounding atmosphere. This is particularly true in a racing situation where the braking events are extreme and frequent. Numerical simulation using both CFD and FEA techniques backed up by extensive dynamometer testing has allowed AP Racing to arrive at a new level of understanding of brake thermal performance and redefine disc design parameters to optimise cooling. We call this "Wide Disc Technology".

Wide Disc Technology is in fact a design tool that allows AP Racing to optimise disc performance. By redistributing the material in the disc, the cooling performance can be significantly improved without increasing weight or stress. Dynamometer and vehicle testing have demonstrated actual temperature reductions of up to 150°C on some applications. The Wide Disc Technology can be applied to any disc brake application and will show worthwhile temperature reductions even where the overall width of the brake package is limited.

- Strap Drive Disc Technology.

This Strap Drive System has been developed by AP Racing



both for Road and Race applications.

The standard fitment discs on many performance cars can suffer from brake vibrations caused by disc distortion. This generally occurs on fast road and track installations.

On many performance cars the typical standard disc will be a heavy duty ventilated single piece casting. Couple this type of rigid disc to a standard hub and wheel bearing and the result is any hub distortion / run out will transfer onto the disc brake faces. This eventually results in brake vibrations, usually picked up through the steering wheel.

The strap drive system offers a new take on the floating systems already in the market place. Strap drive uses a series of stainless steel straps to locate the disc to the mounting bell, producing a flexible coupling between the hub and the disc faces. This allows the disc to run true in the caliper under all conditions and also permits the disc to expand and contract without being restricted.

Some current replacement discs in the market place have evolved from Motorsport applications, they typically use a drive bobbin to provide some disc float and were devised to reduce pad knock off on race cars. This system can work on a road application but there are some major drawbacks that the Strap Drive has overcome with its simplicity. Bobbin float discs rely on a series of drive bobbins moving freely in drive slots. This movement can create wear during service and promote noise. The slots can fill up with road / brake debris causing them to seize. AP Racings strap couplings can't suffer from any of these drawbacks. Therefore Service life, brake noise and also brake pedal travel are all improved.

AP Racing has also introduced the strap drive system into a number of our current brake kit range.

The key points with strap drive discs.

- Compared with single piece discs the disc is de-coupled from hub, this allows disc to align itself perfectly within the caliper.
 - Improved pedal feel and brake response as a result of improved disc alignment within caliper.
 - Improved pedal feel at elevated temperatures as disc rotor is able to expand in a controlled manner with little influence from the disc mounting. This greatly reduces disc coning.
 - Controlled axial float of disc rotor reduces brake 'knock-off' which can result in an inconsistent pedal feel.
 - No free moving parts means that the wear problems normally associated with floating disc designs is not present.
 - No free moving parts means that there are no clearances to become clogged with debris and corrosion which would prevent a conventional floating disc from operating correctly.
 - No free moving parts means no unwanted mechanical noise from discs.
 - Disc rotor and strap sub assembly available as service item for cost effective servicing.
 - Successfully used in race applications.
- Important note: When replacing brake pads with strap drive discs fitted, do not push the pistons back in to the caliper by use of a lever against the discs. If this is done then the disc straps may be distorted and this can cause disc runout, resulting in possible brake vibration

DISC CHOICE

The choice of a particular size and type of disc will depend on the characteristics of the vehicle. Experience with the type of installation or Racing format is very important.

AP Racing has a wealth of experience of all types of Racing and our Technical Section will be pleased to advise on disc choice. Some of the main considerations in this choice are:

HOMOLOGATION AND REGULATION

In Group A and certain other classes of Racing, Brake equipment is restricted to that Homologated by the manufacturer with the FIA. Where applicable you must therefore choose a disc size / type which has been Homologated. E.g. only 4 grooves are allowed in Formula 3.

DISC DIAMETER AND THICKNESS

Disc diameter and thickness are major factors in basic stopping power. Usually the largest diameter disc that can be installed in a particular wheel profile is chosen to maximise braking power unless low weight, poor tyre adhesion or required brake balance dictate otherwise.

Disc thicknesses normally increase with disc diameter and in proportion to vehicle weight and hence work done and cooling required. Standard disc sizes should be used wherever possible as this improves availability.

NOTES

DISC CASTING TYPES

Details of the various disc castings types available from AP Racing are given below to help you choose the correct disc for your application.

NB. AP Racing do not supply unmachined castings, as all disc go through special heat treatments processes during manufacture.

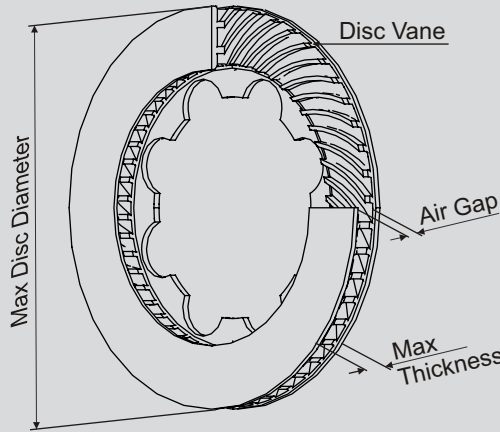

<p>CP2222 Solid with Int/Bell Max Dia = Ø280mm Max Thickness = 22mm</p>	<p>CP2589 Ventilated with Int/Bell. No. of Vanes = 30 Air Gap = 15.25mm Max Dia = Ø280mm Max Thickness = 21mm</p>	<p>CP3047 Ventilated Curved Vane. No. of Vanes = 24 Air Gap = 15.5mm Max Dia = Ø343mm Max Thickness = 32mm</p>	<p>CP3575 Ventilated with Int/Bell. No. of Vanes = 36 Air Gap = 16mm Max Dia = Ø330mm Max Thickness = 36mm</p>
<p>CP3580 Ventilated Curved Vane. No. of Vanes = 48 Air Gap = 14mm Max Dia = Ø330mm Max Thickness = 28mm</p>	<p>CP3581 Ventilated Curved Vane. No. of Vanes = 48 Air Gap = 19.5mm Max Dia = Ø356mm Max Thickness = 36mm</p>	<p>CP3718 Ventilated Curved Vane. No. of Vanes = 48 Air Gap = 17.5mm Max Dia = Ø378mm Max Thickness = 36mm</p>	<p>CP3770 Ventilated Curved Vane. No. of Vanes = 24 Air Gap = 6.5mm Max Dia = Ø280mm Max Thickness = 17mm</p>
<p>CP3781 Ventilated Curved Vane. No. of Vanes = 48 Air Gap = 17.5mm Max Dia = Ø356mm Max Thickness = 36mm</p>	<p>CP3784 Ventilated Curved Vane. No. of Vanes = 48 Air Gap = 16mm Max Dia = Ø378mm Max Thickness = 36mm</p>	<p>CP3836 Ventilated Curved Vane. No. of Vanes = 36 Air Gap = 19.5mm Max Dia = Ø378mm Max Thickness = 36mm</p>	<p>CP3837 Ventilated Curved Vane. No. of Vanes = 36 Air Gap = 15.25mm Max Dia = Ø330mm Max Thickness = 28mm</p>
<p>CP3847 Ventilated Curved Vane. No. of Vanes = 36 Air Gap = 20mm Max Dia = Ø328mm Max Thickness = 32mm</p>	<p>CP3860 Ventilated Curved Vane. No. of Vanes = 60 Air Gap = 18mm Max Dia = Ø310mm Max Thickness = 36mm</p>	<p>CP3870 Ventilated Curved Vane. No. of Vanes = 70 Air Gap = 16.5mm Max Dia = Ø330mm Max Thickness = 36mm</p>	<p>CP3928 Ventilated Curved Vane. No. of Vanes = 28 Air Gap = 8.15mm Max Dia = Ø300mm Max Thickness = 22mm</p>
<p>CP3930 Ventilated Curved Vane. No. of Vanes = 30 Air Gap = 15.5mm Max Dia = Ø343mm Max Thickness = 36mm</p>	<p>CP3948 Ventilated Curved Vane. No. of Vanes = 48 Air Gap = 21mm Max Dia = Ø330mm Max Thickness = 36mm</p>	<p>CP4054 Ventilated Curved Vane. No. of Vanes = 54 Air Gap = 19mm Max Dia = Ø410mm Max Thickness = 36mm</p>	<p>CP4136 Ventilated Straight Vane. No. of Vanes = 36 Air Gap = 9.3mm Max Dia = Ø276mm Max Thickness = 28mm</p>
<p>CP4284 Ventilated Curved Vane. No. of Vanes = 84 Air Gap = 21mm Max Dia = Ø410mm Max Thickness = 36mm</p>	<p>CP4348 Ventilated Curved Vane. No. of Vanes = 48 Air Gap = 9mm Max Dia = Ø315mm Max Thickness = 28mm</p>	<p>CP4378 Ventilated Int/Bell. No. of Vanes = 44 Air Gap = 18mm Max Dia = Ø378mm Max Thickness = 40mm</p>	<p>CP4470 Ventilated Curved Vane. No. of Vanes = 70 Air Gap = 26mm Max Dia = Ø330mm Max Thickness = 42mm</p>
<p>CP4448 Ventilated Curved Vane. No. of Vanes = 48 Air Gap = 10.5mm Max Dia = Ø295mm Max Thickness = 36mm</p>	<p>CP4540 Ventilated Curved Vane. No. of Vanes = 28 Air Gap = 9.0mm Max Dia = Ø315mm Max Thickness = 28mm</p>	<p>RP4542 Ventilated Curved Vane. No. of Vanes = 48 Air Gap = 17.5mm Max Dia = Ø366mm Max Thickness = 32mm</p>	<p>CP4670 Ventilated Curved Vane. No. of Vanes = 70 Air Gap = 22mm Max Dia = Ø330mm Max Thickness = 38mm</p>
<p>CP4914 Ventilated Curved Vane. No. of Vanes = 48 Air Gap = 13.5mm Max Dia = Ø378mm Max Thickness = 36mm</p>	<p>CP5125 Ventilated with Int/Bell. No. of Vanes = 36 Air Gap = 8mm Max Dia = Ø282mm Max Thickness = 23mm</p>	<p>CP5150 Ventilated with Int/Bell. No. of Vanes = 40 Air Gap = 18mm Max Dia = Ø340mm Max Thickness = 38mm</p>	<p>CP5154 Ventilated Curved Vane. No. of Vanes = 54 Air Gap = 20.5mm Max Dia = Ø334mm Max Thickness = 36mm</p>
<p>CP5254 Ventilated Curved Vane. No. of Vanes = 54 Air Gap = 15.25mm Max Dia = Ø334mm Max Thickness = 32mm</p>	<p>CP5772 Ventilated Curved Vane. No. of Vanes = 72 Air Gap = 19.5mm Max Dia = Ø378mm Max Thickness = 36mm</p>	<p>CP6072 Ventilated Curved Vane. No. of Vanes = 72 Air Gap = 25.5mm Max Dia = Ø380mm Max Thickness = 42mm</p>	

DISC FACE TYPES

Disc Grooves and sometimes cross drilling are frequently used on all racing brake discs to clean the surface of the pad & allow gases produced to escape. In doing so the friction characteristics are modified different groove and drilling patterns affect the friction characteristic in different ways, some affect overall friction and others the bite or release characteristics & therefore the best solution is not necessarily the same for each application. AP Racing is constantly developing and refining disc face patterns and new variations will be introduced from time to time. The most popular face types are detailed below.

P = Plain.
(No grooves or holes).
Mainly used for road cars where low noise is vital.

G4,8,12&24 = Grooved.
(Straight forward facing). The number specifies grooves per face. Traditional style groove

CG4, 8, 12 & 24 = Curved Grooves.
(Backward facing)
The number specifies grooves per face.
Standard pattern.

CR4, 8, 12 & 24 = Curved Grooves.
(Backward facing running out on O/D to clear debris. Only used on thick wall discs). The number specifies grooves per face.

RD = Radiused Drilled.
(Cross drilled but with radiused run out to reduce noise & improve life compared with standard cross drilling. Usually used on Road applications.

D = Cross Drilled.
(Drilled holes chamfered). Still preferred with some pad materials but can compromise disc life.

GD = Grooved & Drilled.
Usually used on Road applications.

RA = J Hook Design.
Gives improved bite and debris clearance and reduces distortion / vibration, outer grooves run out to O/D.

GA = J Hook Design.
Latest design gives improved bite & debris clearance & reduces distortion / vibration, outer grooves do not run out to O/D.

RC = J Hook Design.
As RA design but with 3 hooks across face. This design gives improved bite & debris clearance & reduces distortion / vibration.

DISC MOUNTING

Most racing and many high performance road brake discs are designed to be mounted on to the hub or stub axle by means of a mounting bell. Mounting bells are usually made from high grade Aluminium alloy although other materials can be used. This arrangement is much lighter than a one piece disc and bell, but more importantly allows some compliance to reduce the risk of distortion due to heat expansion of the disc.

This becomes more important the larger the disc and is considered essential above Ø330mm diameter.

There are essentially two methods of attaching the disc to the bell, 'Bolted' and 'Floating'. The method to be used will depend on the particular application.

BOLTED

For lower duty applications and on smaller discs a bolted mounting is sometimes preferred for strength and simplicity especially for off-road application (e.g. Rallies) where debris may clog a floating mechanism leading to run-out and disc vibration. Stiff flat bells should be avoided with a bolted mounting.

Standard AP Racing disc mounting hole size is 6.40 / 6.45mm diameter.

AP Racing offer a range of bolts, nuts and washers to suit. These are also available in wheel set kits, see below for details.

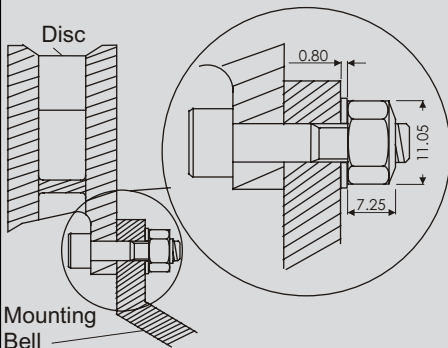

BOLT KITS

Bolt kits available for AP Racing discs are given in the table below. Bolts, nuts and washers are also available separately. **AP Racing recommend a bolt/nut tightening torque for a disc and bell of 14Nm (10.5Lb/ft).**

Bolt kit Part No.	No. of Bolts in kit.	Bolt Part No. (All Bolts 1/4" UNF).
CP2494-24	8	CP2494-116
CP2494-6	12	- .875" long.
CP2494-18	12	CP2494-718
		- 1.0" long.
CP2494-22	12	CP2491-331
		- 1.0625" long.
Nut Part Number.		
CP2494-117 x No of Bolts.		
Stainless Steel Washer Part Number.		
CP2494-1305- 2 x No of Bolts.		

FLOATING

Discs for heavy duty applications, especially larger discs, should be mounted to allow some axial & radial float between disc & bell. This may be achieved by either of two methods:- 'Float in the disc', 'Float in the bell' or 'Strap Drive'.

Radial float allows differential expansion of disc and bell thus reducing stresses in the disc and minimising disc cracking and distortion. The idea of axial float is to compensate for a certain amount of stub axle / upright flex by allowing the disc to take up its ideal position within the range of float thus avoiding 'Knockback' of the caliper pistons. However the float should not be excessive as disc gyroscopic loads can cause the same effect that the float is meant to alleviate.

The amount of axial float will depend somewhat on the application. In a 'perfect' system with minimal disc movement relative to the Caliper the amount of float need only be around 0.15 - 0.25mm.

'FLOAT IN THE DISC'

The AP Racing 'Float in the Disc' system uses a disc with an elongated flat sided mounting hole. The harder disc is less prone to wear than the bell but regular maintenance / cleaning is required if float is to be maintained at the original level.

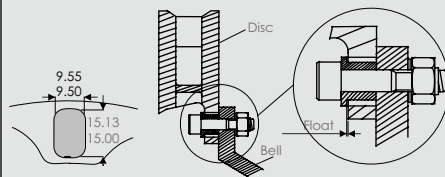

- Float in the disc Bobbins.

The float in the disc bobbins available for AP Racing floating discs are given in the table opposite.

- All bobbin kits comprises 12 each of the following, CP2494-718 bolt, CP2494-117 nut and CP2494-1305 washer and the specified bobbin.

- The exception to this is CP2494-504K10 which has 10 each of CP2494-331 bolt, CP2494-117 nut and CP2494-1305 washer.)

- Tightening torque for bolts is 14Nm (10.5lb/ft).

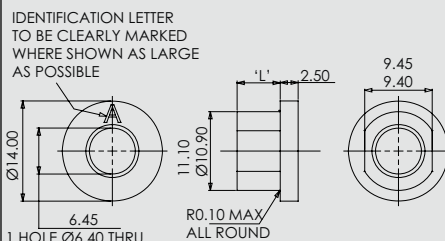

Flange Thick-ness.	Bobbin Part No.	Dim'n 'L'.	Nom Float.	Bobbin Kit Part No.
4.30 / 4.35.	CP2494-595MA	4.70 / 4.75	0.4	CP2494-595K12
4.80 / 4.85.	CP2494-593MB	5.20 / 5.25	0.4	CP2494-593K12
5.00 / 5.05.	CP2494-592MC	5.40 / 5.45	0.4	CP2494-592K12
5.60 / 5.65.	CP2494-1341MD	5.80 / 5.85	0.2	CP2494-1341K12
5.50 / 5.55.	CP2494-591MH	5.90 / 5.95	0.4	CP2494-591K12
5.60 / 5.65.	CP2494-589MJ	6.00 / 6.05	0.4	CP2494-589K12
5.60 / 5.65.	CP2494-626ML	6.30 / 6.35	0.7	CP2494-626K12
6.30 / 6.35.	CP2494-1342MM	6.50 / 6.55	0.2	CP2494-1342K12
6.30 / 6.35.	CP2494-504MP	6.70 / 6.75	0.4	CP2494-504K10
6.30 / 6.35.	CP2494-504MP	6.70 / 6.75	0.4	CP2494-504K12

'FLOAT IN THE BELL'

The AP Racing 'Float in the Bell' system has the advantage of being used with standard bolted discs, float is controlled by bell thickness. During use some wear of the bell inevitably occurs which tends to increase float and requires more frequent Bell replacement than the Float in the Disc system.

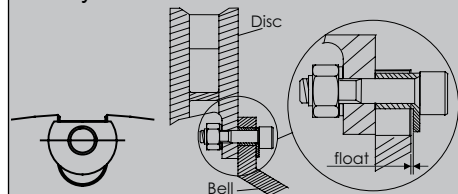

- Float in the bell Bobbins.

The bobbin for use with 'float in the bell' mounting is CP4015-101.

- Bobbin kit CP2494-29

This bobbin can be bought separately or in a kit CP2494-29 which contains the bobbins, bolts, nuts & washers x 12.

NB. Recommended bell flange thickness for use with this bobbin is 8.00 / 8.05 to give 0.15 / 0.25mm float.



WIDE BOBBINS

"Wide Disc" Technology, some discs use the bobbins listed below.

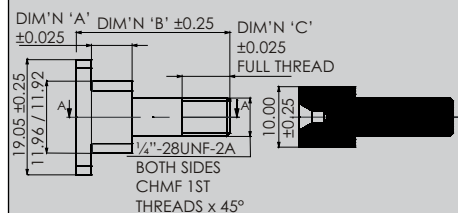

Dim'n 'A'	Dim'n 'B'	Dim'n 'C'	Kit Part No.
5.425	25.4	10.9	CP4015-125MC
6.025	25.4	10.9	CP4015-126MD
6.725	25.4	7.9	CP4015-112MP

DISC OPERATING ADVICE

This section on operating advice has been produced as a guide only, as many formula or racing series may differ.

DISC TEMPERATURES

In order to achieve optimum racing brake performance and prolong disc life it is essential that the brakes operate at the correct temperature. In general discs should run at similar temperatures front and rear and from side to side, dis-similar temperatures will lead to varying brake balance. Temperature balance can be checked as soon as the car stops in the pit lane using a Pyrometer such as AP Racing Pyrometer kit CP2640-24 (see below). However a pyrometer reading is not a good indicator of disc operating temperature which decays rapidly with time when the brakes are not being applied. Under racing conditions disc bulk temperatures should normally be maintained in the range 400°C to 600°C for best performance. Disc face peak temperatures may be higher but should not exceed the maximum recommended for the pad material being used.

An effective method of checking maximum disc operating temperature is by using temperature paints applied to the disc. A suitable paint kit can be obtained under AP Racing Part Number CP2649-1, this kit contains three paints, Green (430°C), Orange (560°C) and Red (610°C) plus thinners and brushes. When assessing brake temperatures it is important to complete several successive laps (5 or preferably 10) at race speeds and vehicle weight to allow temperatures to stabilise at a representative level. Typically when running within the correct temperature range the Green paint (430°) will turn throughout, the Orange paint (560°C) 50% to 100% throughout and the Red paint (610°C) turned up to 5mm from each brake face. If the Red paint (610°C) turns throughout, the discs are running too hot. Circumferential disc face ridges are also an indication of running too hot. Circuits and drivers vary enormously in the amount of work they demand from the brakes and therefore the brake system has to be tuned for each circuit by adjustment of the cooling airflow. The temptation to over cool the disc should be resisted. **The aim is to keep the temperature as stable as possible within the working temperature range.** High maximum to low minimum temperature cycles are the enemy of disc life and cause performance variations.

TEMPERATURE MEASUREMENT - DIGITAL READ-OUT PYROMETER

CP2640-24 Digital pyrometer for brake, disc and tyre



temperatures. High accuracy display reads in centigrade. The unit comes complete with probes for both Brake Discs and Tyres in a heavy duty carry case.

- THERMAL PAINT KITS

CP2649-1 kit comprises of three paints for monitoring peak Brake Disc temperatures.



The three paints are:-

- Green which changes colour to White at 430°C.
- Orange which changes colour to Buff at 560°C.
- Red which changes colour to White at 610°C.

The kit also comprises, one bottle of thinners and three brushes.

- BRAKE CALIPER TEMPERATURE STRIPS

CP2650-11 Temperature indicator strips for monitoring caliper temperatures.



- Temperature range 149°C to 260°C
- Each packet contains 10 strips.

- TEMPERATURE RECORDING PAD

CP2640-25 Allows the user to record temperature data for Brake Discs and Brake Calipers.



DISC COOLING

A good source of cooling air should be supplied preferably through the upright to the disc throat. A typical venting cross section of 100cm² (16in²) is usually sufficient. The pick up should preferably be in an area of clean high pressure air flow and the ducting should be arranged to avoid sharp bends or changes in section which may choke the air flow. Careful design of the Mounting Bell is important in achieving effective disc cooling and avoiding problems.

Typically 80% of the airflow should be directed up the disc vents and 10% up each face of the disc. This ratio can considerably in practice but it is important that both disc faces are cooled equally by adjusting the air gaps.

Unequal face temperatures can lead to disc distortion and a long pedal. Lightening holes in the bells should be avoided as available cooling air can be lost without cooling the disc.

DISC BEDDING

All cast iron brake discs need to be bedded-in to ensure heat stabilisation and improve resistance to cracking. Cracks or even disc failure can occur during the first few heavy stops if careful bedding is not carried out. AP Racing recommend the following procedure:

- 1) If ducts are fitted they should be ¾ blanked off.

- 2) Use previously bedded pads.
- 3) For a minimum of 15Km use brakes gently at first from initially low speeds - Progressively raise speed to normal racing speed but still using gentle applications.
- 4) For the final 2 or 3 applications brakes can be used quite heavily.
- 5) If AP Racing thermal paints are used then only the Green paint (430°C) should have fully turned to white and maybe also just the Orange paint (560°C) on the outside edges of the discs during the bedding procedure.
- 6) Allow to cool.
- 7) AP Racing offer a pre-bedding service at nominal extra charge. This ensures that discs are bedded consistently assuring better performance & life. Contact AP Racing for details.

SAFETY AND CARE OF DISCS

Cast iron brake discs should not normally be operated at bulk temperatures in excess of 610°C and above rotational speeds of 3000 revolutions per minute. Discs must be regularly and frequently inspected for excessive heat crazing and cracking. Discs with cracks emanating from mounting holes / slots, inside diameter, scallops, or outside diameter should be changed immediately. After heavy and prolonged use some surface crazing will often be evident, if this turns into distinct surface cracks which are radiating towards the inside or outside diameter the disc should be changed.

IF IN DOUBT REPLACE.

DISC RUBBING DEPTHS (SWEEP DEPTH)

It is important to match the swept area of the disc to the Pad/Caliper combination that is intended to be used, to avoid any large cold areas which could lead to disc distortion. To make this easier the radial depth of all AP Racing brake pads is incorporated into the part number (the "D" Number e.g. D46, D50 & D54). Normally the Pad / Caliper is positioned so that the top edge of the pad is level with the nominal disc outside diameter. However it is normal to make the eye diameter on the inboard face (Non mounting side) slightly smaller in diameter than the mounting side to match the thermal characteristics of the two disc faces and avoid distortion in use. The amount of this under- hang will vary according to the installation and is part of the disc designers art, but in depth thermal analysis carried out by AP Racing shows that 2mm radius (4mm on diameter) is sufficient in most cases.

N.B. THE PAD SHOULD NEVER OVERHANG THE DISC AS THIS WILL LEAD TO A NUMBER OF BRAKING DIFFICULTIES.

DISC HANDLING.**RIGHT / LEFT HAND IDENTIFICATION**

Most AP Racing brake discs feature curved vanes and are handed. They should be installed with the cooling vanes running back from the inside to outside diameters in the direction of rotation as indicated in the sketch below.

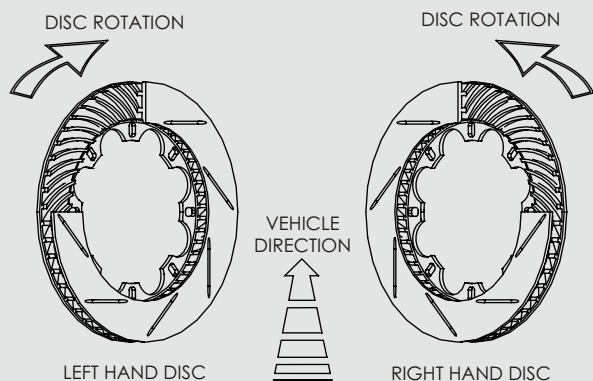
**CUSTOMER NOTES****PART NUMBERING**

When ordering discs please use the correct part number wherever possible. An example part number is explained below:- All AP Racing brake discs are individually marked with the following information:-

**PART NUMBER EXPLANATION**

Basic Disc
(casting) Type

Disc Face Suffix
(see below)

CP3581 - 1042 CG8 B1

Stroke Number

Bedding
(if applicable)

HANDING

- Even Stroke Numbers are Right Hand
- Odd Stroke Numbers are Left Hand

FACE TYPES

- P = Plain
- D = Drilled Face
- G = Straight Grooves G3 = When G appears with a digit, this denotes the number of grooves per face on the disc. e.g. G4 / G6 / CG8 / CR12 etc.
- CG = Curved Grooves
- GD = Grooved & Drilled
- CR = Curved Grooved backward facing running out to O/D.
- RD = Radius Drilled
- SD = Similar to RD but with smaller holes.
- RA = J Hook Design, grooves run-out.
- GA = J Hook Design, grooves do not run-out.
- RC = J Hook as GA but with 3 hooks across face.
- B1 = A "B" and a Number added to the end of the part number i.e. CP3581-1042DB? means the disc has been pre-bedded with a particular pad material.

DISC LISTINGS.

The variety of disc options available provide the solution for virtually every Racing and High Performance Road application. The discs illustrated in these sections are a selection of discs from the range and have been listed by Diameter, Thickness and Mounting Details for convenience. If you are unable to satisfy your requirements from the Discs listed then please contact AP Racing Technical Section for guidance.

VENTILATED BRAKE DISCS

This section on Ventilated Brake Discs provides dimensional details, as well as information on face types and the weight of the most popular discs from the AP Racing disc range. Not all discs are listed, should you require a disc with particular dimensions which is not listed please contact the AP Racing Technical Section for assistance.

Discs which have are highlighted are from the preferred disc range, which offers improved availability and pricing. Please contact AP Racing if you require more information.

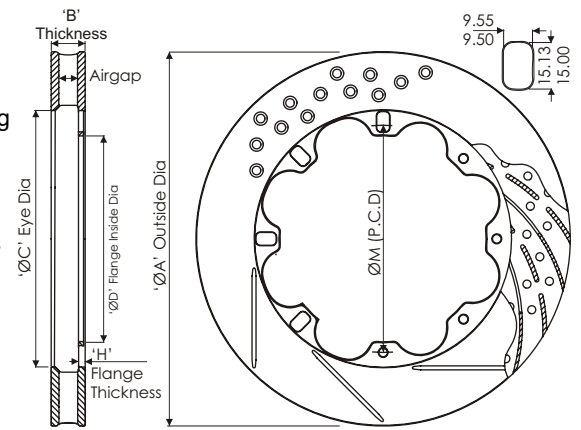

Nominal Dimensions in (mm)															Max Pad Depth.	No. of Vanes.	Air Gap.	Weight Kg.	Face Types Available.	Comments.	Part Numbers.
'A' Outside Dia.	'B' Thick-ness	Mounting Details				'C' Eye Ø.	'D' Inside Flange Ø.	'H' Mtg. Flange Ø.													
		'M' P.C.D.	No.	Fixing type.	Ø.																
254.0	21.0	139.7	6	Bolted	6.4	154.9	125.8	5.6	D46	36	9.3	3.2	G4		CP4136-568						
257.0	21.0	139.7	6	Bolted	6.4	154.9	125.8	5.6	D51	36	9.3	3.6	G4		CP4136-86						
260.0	25.4	139.7	6	Bolted	6.4	154.9	125.8	4.8	D51	48	10.5		G4	Mtg Flange Stepped in 1.2mm	CP4448-226/7						
264.0	21.0	139.7	6	Bolted	6.4	154.9	125.8	5.6	D51	36	9.3	3.7	G4		CP4136-208						
267.0	16.0	162.0	8	Bolted	6.4	180.7	145.0	4.35	D43	24	6.5		CG4		CP3770-1016/7						
	21.0	139.7	6	Bolted	6.4	155.0	125.8	5.6	D54	36	9.3	4.4	G4		CP4136-48						
	28.0	139.7	6	Bolted	6.4	155.0	125.8	4.6	D54	48	10.5		G4		CP4448-81/2						
278.0	16.0	176.1	8	Bolted	8.45	187.4	156.0	4.5	D44	24	6.5	2.5	G4		CP3770-1002/3						
	16.0	181.5	8	Floating	/	194.0	158.0	4.42	D38	24	6.5	2.4	CG4	Bobbin CP2494-595MA	CP3770-1014/5						
280.0	17.0	171.4	8	Floating	/	191.4	146.5	4.42	D43	24	6.5	2.9	CG8	Bobbin CP2494-595MA	CP3770-1018/9						
	17.0	176.8	8	Bolted	6.5	193.5	159.0	4.7	D43	24	6.5	2.5	G8		CP3770-1012/3						
	20.0	176.8	8	Floating	/	192.0	154.0	5.0	D44	48	9.0		D/G4/G8	Bobbin CP2494-592MC	CP4348-862/3						
	21.0	176.8	8	Bolted	6.4	192.0	159.3	4.8	D44	48	10.5		G4	Mtg Flange Stepped out 1.2mm	CP4448-746/7						
	22.2	165.1	8	Bolted	6.4	180.3	152.0	4.6	D50	48	10.5		G4		CP4448-752/3						
	23.0	176.8	8	Bolted	6.4	192.0	159.3	4.8	D44	48	10.5		G4		CP4448-744/5						
	25.4	158.8	8	Bolted	6.4	174.0	141.0	4.8	D51	48	10.5		G4		CP4448-160/1						
	25.4	176.8	8	Bolted	6.4	192.0	159.3	4.9	D44	30	12.9	4.0		CG8	Pro 5000+ Disc	CP5000-312/3					
	25.4	176.8	8	Floating	/	192.0	154.0	5.0	D44	48	14.0	3.5		G4/G8		CP3580-814/5					
	25.4	177.8	12	Bolted	6.4	197.0	164.0	5.8	D41	48	10.5		G4			CP4448-856/7					
25.4	177.8	8	Bolted	6.4	197.0	164.0	4.9	D41	24	15.5	2.7		G8		CP3047-288/9						
285.0	25.4	158.8	8	Bolted	6.4	190.0	141.0	4.6	D61	48	10.5		G4	Mtg Flange Stepped in 1.27mm	CP4448-506/7						
	25.4	177.8	12	Bolted	6.4	197.0	164.0	4.9	D44	24	15.5	3.1	G8		CP3047-276/7						
	28.0	158.8	8	Bolted	6.4	182.5	141.0	6.3	D50	48	10.5		G8		CP4448-268/9						
290.0	28.0	165.1	8	Bolted	6.0	180.0	153.0	5.8	D54	30	15.2	5.1	G4		CP2261-680/1						
	25.4	177.8	12	Bolted	6.4	193.0	164.0	5.9	D46	48	9.0		RD/G4		CP4348-894/5						
295.0	25.4	177.8	12	Bolted	6.4	193.0	164.3	5.8	D51	48	14.0	4.3	RD/G4		CP3580-2894/5						
	25.4	177.8	12	Bolted	6.4	204.0	164.0	5.6	D44	24	9.3	5.4	CG8	Pro 5000+ Disc	CP5000-510/1						
	28.0	177.8	12	Bolted	6.4	193.0	164.0	5.9	D51	36	14.5		G4		CP3837-102/3						
										24	15.5	4.1	G8	Interchangeable	CP3047-256/7						
										48	14.0	5.0	RD/G8		CP3580-102/3						
										48	14.0	5.0	CG8	Bobbin CP2494-1341MD	CP3580-1134/5						
	28.0	177.8	12	Floating	/	192.4	154.0	5.6	D51	48	14.0	5.0	CG8		CP3047-394/5						
	32.0	177.8	12	Floating	/	193.4	153.0	6.3	D51	48	14.0	5.8	CR8	Interchangeable. Bobbin CP2494-504MP	CP3580-394/5						
	300.0	28.0	177.8	12	Bolted	6.4	203.2	164.0	5.6	D46	36	14.5	4.65	G8		CP3837-1004/5					
		20.7	177.8	12	Bolted	6.4	195.0	164.3	5.6	D55	48	9.0		G4		CP4348-626/7					
25.4		177.8	12	Bolted	6.35	201.0	161.0	5.6	D52	24	15.5	3.7	G8		CP3047-404/5						
304.0	25.4	177.8	12	Bolted	6.4	203.2	164.0	4.9	D50	24	15.5		G8	Interchangeable	CP3047-230/1						
							164.3	6.6		48	9.0	G4	CP4348-528/9								
							164.5	4.9		48	14.0	3.7	G8		CP3580-230/1						
							164.0	4.9		36	14.5	4.1	G8		CP3837-230/1						
							24	15.5		4.5	G8	Interchangeable	CP3047-66/7								
	48	14.0	4.9	G8		CP3580-66/7															
	28.0	177.8	12	Floating	/	203.2	152.6	5.6	D50	24	15.5	4.6	G8		CP3047-270/1						
	28.0	190.5	12	Bolted	6.4	210.6	174.0	5.6	D47	48	14.0		G8/RD		CP3580-1080/1						
	32.0	177.8	12	Bolted	6.4	191.0	164.3	6.6	D51	48	14.0		G4		CP3580-2604/5						
	310.0	28.0	190.5	12	Bolted	6.5	210.0	176.0	5.6	D50	24	15.5		G8		CP3047-212/3					
28.0		203.2	12	Bolted	6.4	220.0	190.0	5.6	D46	48	14.0	4.9	G8		CP3580-318/9						
32.0		177.8	12	Bolted	6.4	206.9	163.1	6.3	D51	48	16.5		G8		CP3784-6080/1						
315.0	25.4	203.2	12	Bolted	6.4	220.0	190.0	5.8	D46	24	15.5	3.8	G8		CP3047-328/9						
	28.0	177.8	12	Bolted	6.4	195.1	164.3	5.8	D60	48	14.0	5.9	D/G4		CP3580-2416/7						
	28.0	177.8	12	Bolted	6.4	195.0	164.5	6.6	D60	48	14.0	6.2	G8		CP3580-64/5						
	28.0	177.8	12	Bolted	6.4	210.0	164.3	5.9	D52	36	14.5	4.6	CG8	Pro 5000+ Disc	CP5000-212/3						
	28.0	203.2	12	Bolted	6.4	220.0	190.0	5.6	D46	24	15.5	4.4	G8	Interchangeable	CP3047-178/9						
	48	14.0	5.4	G8		CP3580-178/9															
32.0	177.8	12	Bolted	6.4	210.0	164.0	6.6	D51	24	15.5	6.0	G8		CP3047-216/7							
325.0	28.0	203.2	12	Bolted	6.4	222.0	187.0	6.6	D51	48	14.0	5.8	G4/G8/P/RD		CP3580-294/5						
	32.0	198.0	10	Floating	/	218.0	174.0	6.3	D54	48	16.5	5.8	GA	Bobbin CP2494-504MP	CP3781-2056/7						
	36.0	198.0	10	Floating	/	218.0	174.0	6.3	D54	48	16.5		GA		CP3781-2076/7						

Nominal Dimensions in (mm)														Max Pad Depth.	No. of Vanes.	Air Gap.	Weight Kg.	Face Types Available.	Comments.	Part Numbers.
'A' Outside Dia.	'B' Thickness.	Mounting Details				'C' Eye Ø.	'D' Inside Flange Ø.	'H' Mtg. Flange Ø.												
		'M' P.C.D.	No.	Fixing type.	Ø.															
328.0	28.0	203.2	12	Bolted	6.4	221.8	190.0	5.6	D51	24	15.5	5.2	G4	Bobbin CP2494-504MP	CP3047-372/3					
	32.0	218.0	8	Floating	/	233.1	192.0	6.3	D47	36	19.5		CG8		CP3836-2044/5					
	36.0	184.1	10	Floating	/	200.9	160.0	6.3	D64	70	16.5		GA/RC		CP3870-102/3					
	42.0	184.1	10	Floating	/	200.9	160.0	6.3	D64	70	26.0	8.8	GA		CP4470-102/3					
330.0	25.4	212.0	12	Bolted	6.4	228.0	196.0	5.3	D51	48	14.0	5.2	P		CP3580-1022/3					
	25.4	214.2	12	Bolted	6.4	223.0	201.5	5.3	D46	48	14.0	4.9	G8/GC/RD		CP3580-1040/1					
	25.4	220.5	12	Bolted	6.4	239.2	206.0	5.3	D45	48	14.0		G8		CP3580-1092/3					
	28.0	203.2	12	Bolted	6.4	220.0	190.0	5.6	D54	24	15.5	5.1	G8		CP3047-252/3					
	28.0	203.2	12	Bolted	6.4	227.4	190.0	5.1	D51	36	14.5	4.9	CG8	Pro 5000+ Disc	CP5000-210/1					
	28.0	203.2	12	Bolted	6.4	230.0	190.0	5.6	D50	48	16.5	5.2	G8		CP3781-2002/3					
	28.0	203.2	12	Bolted	6.4	230.0	190.0	5.6	D50	48	14.0	6.2	G8/CG8/RD/T2	Interchangeable	CP3580-2898/9					
	30.0	190.5	12	Bolted	6.4	217.2	172.0	5.575	D56	48	14.0	6.8	CR8		CP3580-1130/1					
	32.0	203.2	12	Bolted	6.4	220.0	190.0	6.6	D54	48	19.5	5.8	G8		CP3581-222/3					
	32.0	203.2	12	Bolted	6.4	228.0	188.0	5.6	D51	36	19.5		G8		CP3836-2014/5					
	32.0	203.2	12	Bolted	6.4	227.4	190.0	6.6	D51	30	15.5	6.7	CG8	Pro 5000+ Disc	CP5000-206/7					
	32.0	203.2	12	Floating	/	227.0	178.0	5.6	D51	48	19.5	5.8	CG8/RA	Bobbin CP2494-589MJ	CP3581-1130/1					
	32.0	203.2	12	Floating	/	226.0	179.0	5.6	D51	48	19.5	5.8	G8		CP3581-1052/3					
	36.0	203.2	12	Bolted	6.4	219.4	190.0	6.6	D54	48	19.5	7.2	CG8	Pro 5000+ Disc	CP5000-112/3					
332.0	32.0	203.2	12	Bolted	6.4	216.8	190.0	5.6	D58	48	19.5		G8		CP3581-766/7					
	32.0	214.0	12	Floating	/	232.8	188.0	5.6	D47	48	19.5		GA	Bobbin CP2494-589MJ	CP3581-1564/5					
343.0	28.0	228.6	12	Bolted	6.4	240.6	212.0	5.3	D51	48	16.5		G8		CP3781-2122/3					
	28.0	228.6	12	Floating	/	246.0	208.0	5.4	D51	48	16.5	5.2	G8	Bobbin CP2494-591MH	CP3781-2036/7					
	32.0	215.9	12	Bolted	6.4	230.0	201.3	5.6	D54	48	19.5	6.1	G8/CG8/CG24/RD		CP3581-542/3					
	32.0	215.9	12	Floating	/	236.0	190.5	5.6	D51	48	19.5	6.0	G8/CG8	Interchangeable, Bobbin CP2494-589MJ	CP3581-564/5					
	32.0	215.9	12	Floating	/	236.0	190.5	5.6	D51	48	16.5		CG8		CP3781-564/5					
355.0	32.0	228.6	12	Bolted	6.4	249.0	208.0	5.6	D47	48	19.5		P		CP3581-1118/9					
	36.0	215.9	12	Bolted	6.4	233.0	195.9	7.5	D54	48	19.5	7.7	G8		CP3581-1082/3					
	28.0	247.6	12	Bolted	6.4	261.6	233.0	5.3	D46	48	16.5	5.1	G8	S1600 Disc Mtg Flange Stepped out 2.5mm, Brembo Mtg	CP3781-2006/7					
	32.0	233.0	10	Floating	/	248.0	217.0	8.0	D51	36	19.5	5.8	G8		CP3836-2018/9					
	32.0	215.9	12	Bolted	6.4	244.0	195.0	6.4	D50	48	17.5	7.3	CG12		CP4542-106/7					
	32.0	228.6	12	Floating	/	244.6	202.8	5.6	D50	72	20.0	6.6	RA	Bobbin CP2494-589MJ	CP5772-1150/1					
	32.0	236.5	12	Floating	/	252.0	211.5	5.6	D51	72	20.0	6.3	GA		CP5772-108/9					
	28.0	228.6	12	Bolted	6.4	238.6	212.0	5.3	D54	48	16.5	5.8	CG12		CP3781-2126-7					
	28.0	228.6	12	Bolted	6.4	261.6	241.0	5.4	D46	48	16.5	5.5	G8		CP3781-2008/9					
	28.0	228.6	12	Floating	/	251.6	202.6	5.0	D51	48	16.5	5.4	CG8	Bobbin CP2494-592MC	CP3781-2024/5					
356.0	28.0	240.0	12	Bolted	6.4	252.6	220.0	5.0	D51	48	16.5	5.3	CG8/RA/RC		CP3781-2142/3					
	32.0	228.6	12	Floating	/	244.6	202.8	5.6	D54	72	19.5	6.6	RA/GA	Bobbin CP2494-589MJ	CP5772-1150/1					
	32.0	228.6	12	Bolted	6.4	245.0	214.0	5.6	D54	48	19.5	6.7	G8/CG24/P		CP3581-536/7					
	32.0	228.6	12	Bolted	6.4	251.0	214.0	5.3	D51	48	19.5		CG8	Pro 5000+ Disc	CP5000-218/9					
	32.0	228.6	12	Floating	/	251.6	202.6	5.6	D51	48	19.5	6.6	G8/CG8	Bobbin CP2494-589MJ	CP3581-1080/1					
	32.0	240.0	12	Bolted	6.4	261.6	225.5	5.6	D46	48	19.5	5.7	G8/P		CP3581-1038/9					
	32.0	240.0	12	Floating	/	258.0	215.0	5.6	D46	48	19.5		CG8	Interchangeable, Bobbin CP2494-589MJ	CP3581-1128/9					
	32.0	240.0	12	Floating	/	258.6	215.0	5.6	D46	72	19.5	5.94	CG12/RA		CP5772-1128/9					
	32.0	240.0	12	Floating	/	261.6	215.0	5.6	D46	36	19.5	5.3	D/G8	Interchangeable, Bobbin CP2494-589MJ	CP3836-2000/1					
	36.0	228.6	12	Bolted	6.4	244.6	214.0	6.6	D54	48	19.5	7.7	CG8	Pro 5000+ Disc	CP5000-110/1					
	36.0	228.6	12	Bolted	6.4	245.0	208.0	6.4	D54	48	19.5	8.3	G8/GD/T2		CP3581-1096/7					
	36.0	228.6	12	Bolted	6.4	245.0	214.0	6.6	D54	48	19.5	8.2	G8	Interchangeable	CP3581-516/7					
	36.0	228.6	12	Bolted	6.4	245.0	214.0	6.6	D54	48	16.5	9.4	G8		CP3781-516/7					
	36.0	228.6	12	Floating	/	244.6	202.8	5.6	D54	48	19.5	7.6	CG8	Interchangeable, Bobbin CP2494-589MJ	CP3581-1136/7					
36.0	228.6	12	Floating	/	251.6	202.6	6.3	D51	72	19.5	7.8	RA		CP5772-1136/7						
36.0	228.6	12	Floating	/	251.6	202.6	6.3	D51	48	19.5	8.0	G8	Bobbin CP2494-626ML	CP3581-1078/9						
360.0	34.0	208.0	10	Floating	/	227.2	182.6	5.6	D65	48	16.0	9.5	CR8	Bobbin CP2494-589MJ	CP3784-128/9					
362.0	32.0	215.9	12	Bolted	6.4	238.0	195.0	6.4	D61	48	17.5	8.4	CG12/G8/P/SD		CP4542-102/3					
	32.0	228.6	12	Bolted	6.4	251.4	208.0	6.5	D54	48	17.5	7.8	G8/RD/T2		CP3718-1068/9					
370.0	36.0	241.3	12	Bolted	6.4	252.0	224.0	6.6	D54	72	19.5	8.56	P/RA		CP5772-6072/3					
375.0	35.0	245.0	10	BREMBO MTG.		261.0	221.0	8.0	D54	72	19.5	8.52	P/RA	Mtg Flange stepped out 1.0mm	CP5772-104/5					
	36.0	241.3	12	Bolted	6.4	257.0	225.0	6.6	D54	72	19.5	8.72	CG8/P/RA/RC		CP5772-6076/7					
	36.0	247.6	12	Bolted	6.4	257.0	231.0	6.6	D54	72	19.5	8.63	P/RA		CP5772-1076/7					
	36.0	260.4	12	Bolted	6.4	269.7	245.0	6.6	D46	72	19.5	7.92	P/RA		CP5772-2702/3					
378.0	32.0	235.8	10	Bolted	8.4	250.0	218.0	7.0	D64	48	16.0		CR8	Interchangeable	CP3784-2098/9					
	32.0	235.8	10	Bolted	8.4	250.0	220.0	7.0	D64	48	17.5		G8		CP3718-2020/1					
	32.0	240.0	12	Floating	/	268.0	215.0	5.6	D54	48	17.5	7.2	CG8	Interchangeable, Bobbin CP2494-589MJ	CP3718-1030/1					
	32.0	240.0	12	Floating	/	268.0	215.0	5.6	D54	72	19.5	7.16	CG8/RA		CP5772-1030/1					
	36.0	260.4	12	Bolted	6.4	282.6	243.8	5.8	D48	36	19.5	5.8	GA		CP3836-2002/3					
	36.0	240.0	12	Floating	/	264.0	216.0	5.6	D54	72	19.5	8.9	CG8/CR24/RA	Bobbin CP2494-589MJ	CP5772-2068/9					
380.0	32.0	240.0	12	Floating	/	266.0	215.0	5.6	D56	72	19.5		G8		CP5772-1032/3					
	32.0	228.6	10	Floating	/	247.0	202.2	5.6	D66	72	19.5	8.4	CG8	Bobbin CP2494-589MJ	CP5772-118/9					
	37.0	240.0	12	Floating	/	270.0	215.0	5.4	D54	72	25.5	7.6	CG24/GA		CP6072-108/9					
	38.0	240.0	12	Floating	/	268.8	215.5	5.4	D55	72	25.5	8.2	CR24/RC	Bobbin CP2494-4015-126MD	CP6072-110/1					
390.0	36.0	260.0	12	Bolted	6.4	268.8	243.0	6.3	D54	72	25.5	8.8	CR24/RA		CP6072-102/3					
390.0	36.0	260.0	12	Bolted	6.4	268.8	243.0	6.3	D54	54	19.0	7.9	CG8/CG24		CP4054-1076/7					

SOLID BRAKE DISCS

This section on solid brake discs provides dimensional details, as well as information on face types and the weight of the most popular discs from within the solid disc range. Not all solid discs are listed, should you require a disc with particular dimensions which is not listed please contact AP Racing Technical Section for assistance.

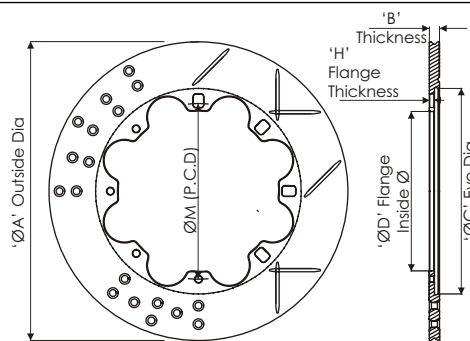

Nominal Dimensions in (mm)													
'A' Outside Dia.	'B' Thickness	Mounting Details				'C' Eye Ø.	'D' Inside Flange Ø.	'H' Mtg. Flange Ø.	Max Pad Depth.	Weight Kg.	Face Types Available.	Comments.	Part Numbers.
		'M' P.C.D.	No.	Fixing type.	Ø.								
248.0	7.0	146.0	8	Bolted	8.45	162.0	131.0	6.0	D44	G4	Mtg Flange Stepped out 2.5mm	CP2866-211	
	7.1	151.0	8	Bolted	6.4	169.7	134.0	6.9	D38	G4	Mtg Flange Stepped out 2.4mm	CP2866-205	
254.0	8.0	146.0	8	Bolted	8.35	162.0	131.0	6.0	D46	G4	Mtg Flange Stepped out 0.75mm	CP2866-230	
	8.0	146.0	8	Bolted	8.45	165.0	131.0	6.0	D44	G4	Mtg Flange Stepped out 2.0mm	CP2866-215	
	8.0	146.0	8	Bolted	8.45	165.0	131.0	6.0	D44	G4	Mtg Flange Stepped out 0.75mm	CP2866-218	
	9.7	151.0	8	Bolted	6.4	166.0	134.0	4.8	D44	G4		CP2866-204	
	9.7	146.0	8	Bolted	8.5	166.0	131.0	6.0	D44	G4		CP2866-210	
260.0	9.5	139.7	6	Bolted	7.95	172.7	123.2	5.1	D44	G4		CP2866-229	
265.0	7.1	158.8	8	Bolted	6.4	177.0	141.0	4.8	D44	D/G4		CP2866-195	
	8.0	158.8	8	Bolted	6.4	189.0	141.0	4.8	D38	G8		CP2866-214	
	9.6	158.8	8	Bolted	6.4	177.0	141.0	4.8	D44	D/G4/G8/P		CP2866-179	
	9.6	158.8	8	Floating	/	177.0	135.7	4.8	D44	D/G4/G8/P	Bobbin CP2494-593MB	CP2866-193	
277.0	9.6	176.8	8	Bolted	6.4	192.0	159.0	4.8	D43	G4/G8		CP2866-178	
	9.6	176.8	8	Floating	/	192.0	154.0	4.8	D43	G4/G8	Bobbin CP2494-593MB	CP2866-192	
	9.6	181.5	8	Floating	/	197.6	159.3	4.8	D40	G4	Bobbin CP2494-593MB	CP2866-203	
280.0	9.6	169.8	8	Floating	/	192.0	149.3	4.8	D44	G4	Bobbin CP2494-593MB	CP2866-194	
	9.6	175.0	8	Bolted	6.4	191.5	158.0	4.8	D44	D/G4		CP2866-223	
	9.6	176.8	8	Bolted	6.4	192.0	159.0	4.8	D44	D/G4/G8		CP2866-177	
	9.6	176.8	8	Bolted	6.4	192.0	159.0	4.8	D44	CG4	Pro 5000+ Disc	CP5000-177	
	9.6	190.0	8	Bolted	6.4	206.0	176.0	4.8	D36	D/G8		CP2866-197	
	10.0	190.0	8	Floating	/	206.0	173.0	4.8	D36	D/G8	Bobbin CP2494-593MB	CP2866-202	
300.0	9.6	189.0	8	Bolted	6.4	206.5	171.0	4.6	D46	D		CP2866-196	
304.0	9.6	200.0	10	Bolted	6.4	216.0	186.5	4.8	D44	CG8/D		CP2866-217	

SOLID BRAKE DISCS WITH INTEGRAL MOUNTING BELL

This section on solid brake discs with integral mounting bell provides dimensional details, as well as information on face types and the weight of the most popular discs from within the solid integral disc range. Not all discs are listed, should you require a disc with particular dimensions which is not listed please contact the AP Racing Technical Section for assistance.

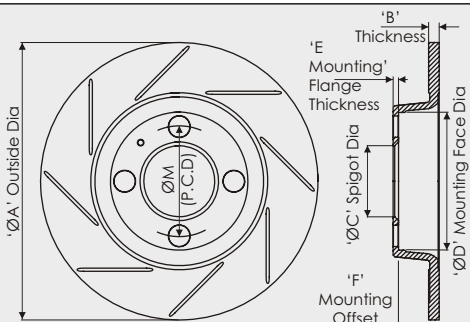

Nominal Dimensions in (mm)												
'A' Outside Dia.	'B' Thickness	Mounting Details			'C' Spigot Dia.	'D' Mtg Face Dia.	'E' Mtg Flange Thickness.	'F' Mtg Offset.	Max Pad Depth.	Weight Kg.	Face Types.	Part Number.
		'M' P.C.D.	No.	Dia.								
248.0	7.1	95.25	4	9.5	76.2	128.0	5.1	32.5	D46	2.4	P	CP2222-9
	7.1	100.0	4	12.5	76.2	127.7	5.1	32.65	D43	2.5	G4	CP2222-272
254.0	9.7	95.25	4	9.5	76.2	128.0	5.1	31.5	D46	3.3	P	CP2222-10
	9.7	95.25	4	9.7	76.2	129.5	5.1	31.5	D50	3.3	P	CP2222-262
	9.7	100.0	4	12.5	72.6	127.7	5.1	31.5	D43	2.8	G4	CP2222-273
264.0	11.1	107.95	4	11.6	86.36	133.35	7.87	16.8	D52	3.8	P	CP2407-129
266.0	9.0	100.0	4	13.2	65.16	128.3	5.1	26.9	D45		P	CP2407-236

VENTILATED BRAKE DISCS WITH INTEGRAL MOUNTING BELL

This section on ventilated brake discs with integral mounting bell provides dimensional details, as well as information on face types and the weight of the most popular discs from within the ventilated integral disc range. Not all discs are listed, should you require a disc with particular dimensions which is not listed please contact the AP Racing Technical Section for assistance.

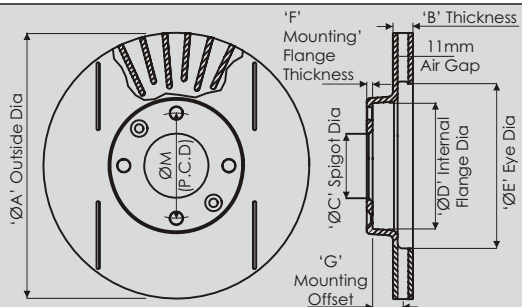

Nominal Dimensions in (mm)													
'A' Outside Dia.	'B' Thickness	Mounting Details			'C' Spigot Dia.	'D' Internal Flange Dia.	'E' Eye Dia.	'F' Mtg Flange Thickness.	'G' Mtg Offset.	Max Pad Depth.	Weight Kg.	Face Types.	Part Number.
		'M' P.C.D.	No.	Dia.									
254.0	20.7	100.0	4	14.7	62.0	121.3	170.0	8.2	38.2	4.3	G4	CP2589-120	
262.0	20.1	108.0	4	12.9	66.1	131.0	156.0	6.0	31.0	4.2	G4	CP2589-115	
270.0	22.0	108.0	4	12.4	65.26	129.1	165.0	6.0	30.7	4.8	G4 / G8	CP2589-138	
273.0	20.5	108.0	4	12.9	66.1	129.0	169.0	6.0	30.2	4.5	G4	CP2589-135	



INTRODUCTION

AP Racing's Competition and High Performance Brake systems have been developed with the benefit of our unparalleled experience in racing and performance brake technology to respond to the severe demands encountered under competitive and road conditions. The friction material used in a brake system is a vital factor in the overall performance of that system and it is therefore important to choose the correct pad for the particular application. As a major manufacturer of brake systems for competition and high performance vehicles, AP Racing is in a unique position to evaluate brake pad performance both on its own dynamometer test beds and on vehicles. AP Racing policy is to offer a range of the best friction materials currently available from whatever source.

GENERAL INFORMATION.

Pages 58 to 61 provide details on the range of pads and friction materials for competition and road use when using AP Racing brake calipers. This section also includes information to assist in the selection of the most suitable pad for a given application:-

- Temperature ranges and measurement.
- Advice on Brake noise.
- Bedding in' procedures.
- Correct pad shape for a given AP Racing caliper.

- Friction material choice.

AP Racing Technical Section will be pleased to advise on the most suitable equipment for any particular application and can provide more detailed technical information if required.

(For part numbering / ordering details please refer to page 61 .)

PAD CHARACTERISTICS

This section is intended to assist in the selection of the most suitable friction material for your application. There are numerous characteristics associated with friction materials, few of which are absolute, for example the friction Coefficient (μ) varies depending on temperature, speed, pressure and energy level and no two dynamometer programmes will ever

produce quite the same results. Choosing the most suitable pad for your application is a complex problem requiring careful evaluation of all the available information. To help you with this AP Racing have developed a rating system for the principal pad characteristics incorporating both the experience gathered by our engineers over many years and our special dynamometer evaluation carried out in-house on our state of the art facility. The AP Racing dynamometer brake pad evaluation is based around a series of 14 stops which represent the full range of conditions likely to be experienced in use. A composite dynamometer plot and an explanation of the AP Racing evaluation and rating systems is given below and on the page opposite.

COMPOSITE DYNAMOMETER PLOT.

This material shows relatively poor friction from cold improving as the pad heats up.

This material has a good friction level but a climbing (non user friendly) plot and poor initial bite relative to the average friction level.

This material exhibits slight fade but still maintains a relatively high friction level.

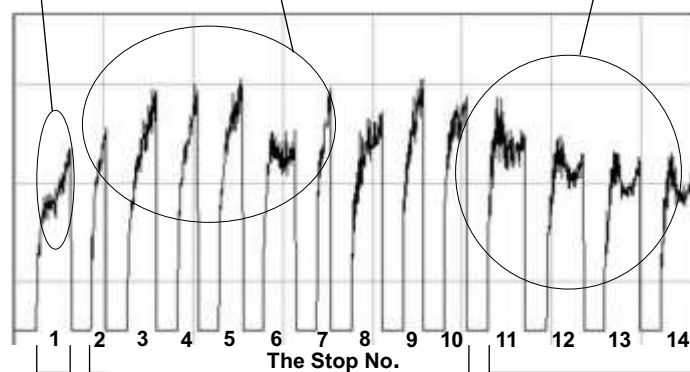

Very severe high speed stop from cold. (Cold Performance)

Variety of stops ranging in severity from light to very severe.

Very severe stops from high speed to demonstrate fade capabilities.

AVERAGE FRICTION.

Overall mean friction coefficient calculated over the complete test cycle.

"BITE".

Initial friction at the start of the stop. Rating 1 to 5. (5 = Good, 1 = Poor)

FADE.

Drop off in friction coefficient from stop to stop when used for very hard braking. Calculated from last 4 stops on test plot on a scale of 1 to 5. (5 = No significant fade)

AVERAGE PAD WEAR.

A comparative rating of pad wear across all conditions. Rated on a scale

PLOT SHAPE

The shape of the friction plot during a brake application. High initial "bite" with friction gradually decreasing through the stop as speed drops off is considered to be the easiest to control (most "user friendly"). A climbing friction level through

the stop is considered the most difficult to control (least "user friendly") although some pads with this characteristic are extremely popular due to their overall high friction level and fade resistance. Rated on a comparative scale of 5 to 1.

High initial "bite" with friction gradually reducing & stabilising through the stop. Most "user friendly". Rating 5

Essentially flat plot. Rating 3.

Steeply rising plot. Least "user Friendly". Rating 1.

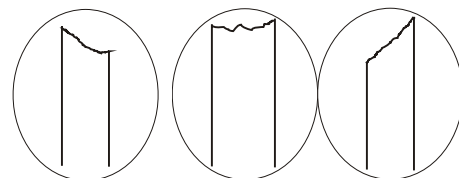

COMFORT / NOISE

Does the pad promote judder or brake squeal ?. Important on road car applications but not usually a consideration for

racing use. Rated subjectively on a scale from 1 to 5 (5 = no noise / judder).

DISC LIFE

Does the pad promote high disc wear or cracking ?. Especially important on road car applications. Rated on a scale of 1 to 5 (5 = best).

EFFECTIVE TEMPERATURE RANGE

The temperature range within which the pad material can be considered effective should be

used as a comparative guide only as temperature measurement techniques vary significantly and the true picture must include the energy level (quantity of heat). Pad temperatures are affected by disc mass and cooling. Rated 1 to 5 (1 = 200°C, 2 = 350°C, 3 = 500°C, 4 = 650°C and 5 = 800°C).

SUITABLE AREA OF USE

The areas for which the pad material is considered most suitable.

This is a subjective assessment relying on the pooled experience of AP Racing engineers over many years. Contact AP Racing Technical Section for guidance.

PAD MATERIAL PERFORMANCE

The table overleaf provides the ratings given for the characteristics described on the this page. The table results are AP Racing's own, determined from our dynamometer testing and may differ from manufacturers own specifications.

Pad Mat'l.	Performance			Characteristics.			Wear.	Temp Range.	Suitable For.								
	Ave Friction Mu.	Bite.	Fade.	Plot Shape.	Comfort / Noise.	Disc Life.			Ave Wear.	Temp Rating.	Light Comp.	F3 / (T.Car Rear).	T.Car Front.	Sports Car.	Rally.	Grp 'N'	Hill Climb.
AP Racing Pad Materials.																	
APF101	0.49	4	5	4	3	3	5	5									
APF102	0.39	5	3	5	3	3	4	4									
APF103	0.47	4	4	4	3	3	3	4									
Hawk Pad Materials.																	
HT10	0.36	2	2	3	2	1	1	5									
HT14	0.35	4	4	4	3	3	3	3									
Ferodo Pad Materials.																	
4003F	0.43	3	3	4	4	2	3	2									
3432F	0.39	3	3	2	4	1	3	3									
DS2500	0.34	3	3	4	5	4	3	2									
DS3000	0.42	2	2	4	3	3	3	4									
DS3000+	0.41	3	3	3	3	4	2	4									
DS3000E	0.37	3	3	3	3	4	4	4									
DS1.11	0.43	2	3	1	3	4	4	4									
Mintex Pad Materials.																	
F1R	0.46	4	4	3	3	4	4	4									
F2R	0.42	4	4	3	3	4	4	4									
F4R	0.47	4	4	3	3	4	4	3									
M1166	0.38	3	3	3	2	3	3	3									
Pagid Pad Materials.																	
RS14	0.39	3	4	3	4	5	4	3									
RS4-2	0.35	4	2	4	3	4	4	3									
RS421	0.29	3	3	5	4	5	4	2									
Raybestos Pad Materials.																	
ST39	0.40	2	2	2	3	3	2	2									
ST41	0.42	5	3	4	3	4	4	4									
ST42	0.37	5	4	4	3	3	4	4									
ST43	0.39	5	3	5	3	3	4	4									
Other Friction Materials.																	
RQ3	0.41	3	5	3	5	4	3	2									
APH420	0.39	3	5	3	5	4	4	2									
SRR	0.46	5	4	5	5	4	1	3									

BRAKE PAD TEMPERATURES

An important factor in consistent brake performance is maintaining the operating temperatures within the effective range of the pad material being used by controlling the flow of cooling air from the brake ducts. There are several different methods of monitoring the brake system temperatures:-

1. THERMAL PAINTS
2. BRAKE TEMPERATURE PYROMETER
3. TEMPERATURE STRIPS

For more detailed information of these methods please go to page 53.

'BEDDING IN' PROCEDURES RACE FRICTION MATERIALS

AP Racing offer a large variety of the best friction materials currently available from various sources to suit every racing condition. It is therefore very difficult to recommend a common 'Bedding in' procedures suitable for all friction materials. Please refer to the manufacturers own 'Bedding' information for guidance.

ROAD FRICTION MATERIALS

For Pads for AP Racing brake calipers or kits use the following procedure:- Bed the pad and disc contact areas by using moderate brake applications for 80Km (50 miles), avoiding excessive speeds, building the stopping power and vehicle speed gradually over the next 80Km (50 miles). This will ensure maximum pad performance and disc life.

FOR AN OE PAD PLEASE REFER TO

THE MANUFACTURERS OWN INSTRUCTIONS.

BRAKE NOISE

Brake noise or squeal is a vehicle system problem since the severity, regularity and tone is a function of the brake and suspension components in combination. This does not represent a problem on competition vehicles where performance is the primary objective but is generally unacceptable for road use. Some vehicles are particularly susceptible to the problem. The contact between the pad and disc during braking creates the raw energy to produce the noise but the actual squeal can be primarily or a combination of the disc, caliper and pad. Elimination of squeal under all brake operating conditions is difficult to achieve when specifying a brake package whose purpose is to safely absorb very high energy inputs. A number of methods are available to reduce the noise factor of a brake system but assuming the base vehicle suspension system is settled, the reduction or elimination of noise is usually achieved by a process of trial and error. The first and easiest solution to try is the addition of high temperature grease to the back of the pad to provide a damping medium between the piston and pad.

Typically Copper Slip is applied although care must be taken to avoid any grease coming into contact with the pad face. The use of high friction brake pads such as Pagid RS4-2 / M1177 creates high energy at the friction interface which can characteristically lead to more brake squeal but some pads are typical for their lower noise rating. These pads are characterised by their lower friction

coefficient and reduced initial 'bite'.

Examples of such a materials is Ferodo 3432F. There are a number of disc variants available from AP Racing and the type chosen can have an effect on brake noise, depending again on the pad choice. Generally it is found the multi drilled or grooved discs used in conjunction with competition pads will give unacceptable noise levels for road use, Plain face discs can cause higher levels of squeal, as the pad is not cleaned by the actions of holes or grooves. For the AP Racing Formula Big Brake it conversions, we have found a reduced drill pattern with a radiused edge and using Ferodo DS2500 pads give little or no pad noise and still have good performance. Where the noise is a function of the brake pad temperature, characterised by the noise reducing (possibly to zero) as the brakes are used more severely. The pad may also respond to the addition of pad chamfers which reduce the effective pad area and change the pad shape / centre of pressure. These chamfers (10,0mm x 30 degrees) can be added to the leading edge first and their effect assessed prior to the addition of a chamfer on the trailing edge. Please contact AP Racing technical section for details of availability and specific requirements.

ANTI-SQUEAL SHIMS

Anti squeal shims are very effective and CP5070 pad family have them fitted as standard. Anti squeal shims are also available for other pad families, but if you experience noise using other pad families please contact the road car technical section for further advice

BRAKE PADS TO SUIT AP RACING BRAKE CALIPERS

The tables opposite provide details of the complete range of AP Racing brake calipers and the correct pad shape to suit each caliper in the range. As well as providing information on current calipers, the table also includes all the obsolete AP Racing calipers.

(Calipers no longer in production or no longer available from AP Racing), and gives the correct pad family number where still available. Please refer to the table on page 61 to ensure that the pad shape is still available. When using the chart the following points should be noted:-

1. Some installations require the use of a 'Scalloped' version of the given pad family. In these cases the full area pad cannot be used.
2. In most cases a thinner version of the original pad can be used as an alternative.
3. A 'Scalloped' pad (smaller radial depth) can usually be used in place of the full area pad but may affect ultimate performance.

NB Inclusion of a caliper in this list does not indicate availability.

Caliper Family No.	Pad Family No.	Caliper Family No.	Pad Family No.	Caliper Family No.	Pad Family No.	Caliper Family No.	Pad Family No.	Caliper Family No.	Pad Family No.	Caliper Family No.	Pad Family No.	Caliper Family No.	Pad Family No.
CP2195	CP2195	CP3025	CP2279	CP3449	CP2340	CP3697	CP3195	CP4270	CP2270	-56 / -59	CP3215	CP5866	CP4970
CP2270	CP2270	CP3026	CP2279	CP3455	CP2279	CP3704	CP3714	CP4279	CP2279	-74 / -77	CP3215	CP5870	CP4970
CP2271	CP2270	CP3044	CP2399	CP3456	CP2340	CP3705	CP3714	CP4280	CP2420	CP5006	CP3215	CP5880	CP2279
CP2279	CP2279	CP3045	CP2372	CP3459	CP2340	CP3708	CP2279	CP4288	CP4288	CP5015	CP3714	CP5890	CP4595
CP2290	CP2279	CP3048	CP2279	CP3463	CP2279	CP3714	CP3714	CP4289	CP4288	CP5016	CP3714	CP5890	CP4970
CP2340	CP2340	CP3086	CP3085	CP3465	CP2279	CP3715	CP3714	CP4296	CP4296	CP5017	CP3714	CP5970	CP4970
CP2361	CP2340	CP3088	CP3086	CP3470	CP3215	CP3720	CP3215	CP4409	CP2279	CP5018	CP3714	CP5971	CP4970
CP2372	CP2372	CP3089	CP2279	CP3471	CP2279	CP3721	CP2279	CP4466	CP4466	CP5020	CP2399	CP5990	CP5788
CP2373	CP2372	CP3090	CP2279	CP3475	CP3215	CP3725	CP2279	CP4469	CP4466	CP5030	CP4296	CP6030	CP2340
CP2382	CP2372	CP3093	CP2279	CP3477	CP2340	CP3727	CP3215	CP4477	CP4466	CP5040 RANGE			
CP2383	CP2372	CP3094	CP2279	CP3479	CP2340	CP3733	CP3215	CP4484	CP4484	-2 / -5	CP3215	CP6040	CP4970
CP2384	CP2372	CP3107	CP3107	CP3480	CP2279	CP3735	CP2340	CP4485	CP4484	-10 / -13	CP3345	CP6042	CP4970
CP2385	CP2340	CP3118	CP2279	CP3481	CP2340	CP3736	CP2279	CP4488	CP4488	-20 / -23	CP3714	CP6044	CP4970
CP2399	CP2399	CP3129	CP2340	CP3482	CP2340	CP3737	CP2340	CP4554	CP3558	-30 / -33	CP2279	CP6050	CP6050
CP2409	CP2279	CP3138	CP2279	CP3483	CP2279	CP3738	CP2279	CP4556	CP2340	CP5045	CP5045	CP6051	CP6050
CP2425	CP2270	CP3139	CP2279	CP3484	CP2279	CP3746	CP2702	CP4558	CP2340	CP5060	CP3894	CP6055	CP4240
CP2485	CP2399	CP3140	CP2279	CP3485	CP3086	CP3750	CP3215	CP4567	CP3345	CP5070	CP5070	CP6056	CP3558
CP2505	CP2195	CP3148	CP2340	CP3488	CP2279	CP3755	CP3554	CP4575	CP3558	CP5090	CP2279	CP6060	CP6210
CP2561	CP2554	CP3160	CP2749	CP3489	CP2279	CP3760	CP2279	CP4576	CP3558	CP5100	CP3345	CP6065	CP6210
CP2562	CP2554	CP3161	CP2749	CP3490	CP2279	CP3769	CP3086	CP4577	CP3558	CP5104	CP2340	CP6070	CP6070
CP2564	CP3714	CP3162	CP2749	CP3495	CP2279	CP3779	CP2561	CP4586	CP2399	CP5108	CP3345	CP6071	CP6070
CP2570	CP2372	CP3163	CP2749	CP3496	CP2270	CP3788	CP2279	CP4595	CP4595	CP5111	CP5111	CP6075	CP6230
CP2575	CP2270	CP3166	CP2749	CP3498	CP2279	CP3789	CP2279	CP4596	CP2399	CP5116	CP5234	CP6080	CP4970
CP2576	CP2399	CP3167	CP2749	CP3525	CP2279	CP3790	CP2279	CP4597	CP2749	CP5120	CP3345	CP6086	CP6210
CP2577	CP2399	CP3170	CP2279	CP3536	CP2340	CP3796	CP3796	CP4598	CP4595	CP5130	CP2340	CP6087	CP4970
CP2578	CP2372	CP3172	CP2279	CP3545	CP2340	CP3799	CP2279	CP4599	CP4595	CP5144	CP2340	CP6088	CP3558
CP2586	CP2399	CP3176	CP2399	CP3546	CP2279	CP3800	CP3800	CP4604	CP3714	CP5145	CP2279	CP6096	CP4240
CP2587	CP2399	CP3177	CP2399	CP3548	CP3548	CP3801	CP2279	CP4605	CP3714	CP5146	CP5070	CP6096	CP3558
CP2600	CP2195	CP3178	CP2399	CP3549	CP3549	CP3804	CP3714	CP4608	CP3558	CP5147	CP2340	CP6096	CP4240
CP2601	CP2195	CP3185	CP3086	CP3552	CP2749	CP3805	CP3714	CP4611	CP3894	CP5148	CP5148	CP6096	CP4970
CP2632	CP2887	CP3186	CP3086	CP3553	CP2279	CP3809	CP2279	CP4612	CP3894	CP5200	CP3215	CP6114	CP5119
CP2636	CP2279	CP3207	CP3207	CP3554	CP3555	CP3814	CP3714	CP4614	CP3714	CP5205	CP3215	CP6119	CP5119
CP2639	CP2279	CP3208	CP2086	CP3555	CP3558	CP3815	CP3714	CP4615	CP3714	CP5209	CP3215	CP6120	CP5119
CP2645	CP2645	CP3209	CP2279	CP3556	CP2340	CP3820	CP2279	CP4620	CP3215	CP5210	CP3894	CP6121	CP5119
CP2661	CP2340	CP3216	CP3215	CP3557	CP2279	CP3825	CP3800	CP4621	CP3558	CP5211	CP2399	CP6148	CP5148
CP2667	CP2399	CP3228	CP2340	CP3564	CP2340	CP3827	CP3800	CP4624	CP3714	CP5218	CP2399	CP6220	CP6220
CP2696	CP2195	CP3239	CP2279	CP3565	CP2340	CP3830	CP3800	CP4638	CP3696	CP5230	CP5230	CP6230	CP6230
CP2698	CP2372	CP3240	CP2279	CP3566	CP2279	CP3846	CP2340	CP4648	CP2195	CP5234	CP5234	CP6234	CP5234
CP2699	CP2372	CP3245	CP2749	CP3567	CP2340	CP3855	CP3554	CP4649	CP2195	CP5235	CP5119	CP6235	CP6235
CP2702	CP2702	CP3248	CP3248	CP3569	CP3086	CP3876	CP2399	CP4666	CP3666	CP5260	CP3558	CP6240	CP6230
CP2712	CP2712	CP3249	CP2279	CP3570	CP2340	CP3879	CP2561	CP4680	CP4860	CP5266	CP5166	CP6315	CP3894
CP2735	CP2195	CP3257	CP3215	CP3577	CP2340	CP3884	CP3894	CP4689	CP3679	CP5270	CP3558	CP6320	CP3215
CP2736	CP2702	CP3259	CP2749	CP3578	CP2279	CP3895	CP3894	CP4690	CP3215	CP5300	CP2564	CP6340	CP3215
CP2749	CP2749	CP3286	CP3215	CP3579	CP2279	CP3896	CP3894	CP4695	CP3558	CP5308	CP2564	CP6350	CP6230
CP2750	CP2749	CP3288	CP3215	CP3584	CP2279	CP3897	CP3894	CP4698	CP4595	CP5310	CP2399	CP6360	CP6210
CP2751	CP2749	CP3307	CP3215	CP3585	CP2340	CP3939	CP2279	CP4699	CP4595	CP5311	CP2399	CP6361	CP6210
CP2752	CP2749	CP3312	CP3215	CP3586	CP3086	CP3969	CP3086	CP4704	CP3714	CP5320	CP6600	CP6420	CP3215
CP2755	CP2749	CP3315	CP2279	CP3587	CP2340	CP3970	CP4970	CP4705	CP3714	CP5410	CP7735	CP6508	CP6508
CP2756	CP2749	CP3317	CP2279	CP3589	CP2279	CP3974	CP4970	CP4714	CP3714	CP5510	CP7735	CP6520	CP3215
CP2757	CP2749	CP3326	CP3215	CP3596	CP3596	CP3977	CP4970	CP4715	CP3714	CP5515	CP7735	CP6560	CP3215
CP2758	CP2749	CP3338	CP2340	CP3599	CP2340	CP3980	CP6210	CP4720	CP3797	CP5555	CP3894	CP6561	CP3345
CP2770	CP2195	CP3343	CP2279	CP3601	CP6301	CP3996	CP3596	CP4725	CP3215	CP5560	CP3894	CP6562	CP3215
CP2824	CP2340	CP3344	CP2340	CP3604	CP3714	CP4020	CP3215	CP4728	CP3558	CP5566	CP4466	CP6564	CP3215
CP2830	CP2830	CP3345	CP2340	CP3605	CP3714	CP4066	CP2340	CP4751	PF751	CP5570	CP3894	CP6600	CP6600
CP2831	CP2270	CP3348	CP2340	CP3608	CP2279	CP4068	CP2340	CP4760	CP3797	CP5575	CP5070	CP6602	CP6600
CP2832	CP2749	CP3349	CP2340	CP3609	CP2279	CP4069	CP4070	CP4761	PF751	CP5577	CP4466	CP6605	CP6600
CP2833	CP2479	CP3355	CP2340	CP3614	CP3714	CP4090	CP3894	CP4771	PF751	CP5580	CP3894	CP6608	CP6600
CP2843	CP2749	CP3358	CP2340	CP3615	CP3714	CP4096	CP3894	CP4781	PF751	CP5588	CP4466	CP6609	CP6600
CP2852	CP2399	CP3359	CP2340	CP3617	CP2399	CP4097	CP3894	CP4790	CP3714	CP5589	CP3215	CP6611	CP6600
CP2854	CP2554	CP3360	CP2749	CP3618	CP2340	CP4098	CP3894	CP4795	CP3558	CP6610	CP7735	CP6688	CP6688
CP2862	CP2399	CP3364	CP2340	CP3619	CP2340	CP4100	CP2554	CP4844	CP4844	CP6611	CP3894	CP6720	CP3215
CP2868	CP2868	CP3365	CP2279	CP3620	CP3215	CP4120	CP2399	CP4848	CP4848	CP6620	CP3215	CP6730	CP3215
CP2870	CP2870	CP3368	CP2279	CP3629	CP2195	CP4130	CP4296	CP4849	CP4848	CP6630	CP3894	CP6740	CP3215
CP2876	CP2270	CP3369	CP3086	CP3634	CP2279	CP4131	CP4296	CP4879	CP2399	CP6666	CP3666	CP6751	CP7751
CP2877	CP2279	CP3375	CP2279	CP3635	CP2279	CP4132	CP4296	CP4890	CP3215	CP6689	CP3215	CP6760	CP3345
CP2879	CP2554	CP3378	CP2340	CP3636	CP2279	CP4140	CP4140	CP4894	CP3894	CP6710	CP7735	CP6761	CP7751
CP2887	CP2340	CP3379	CP2340	CP3637	CP2340	CP4144	CP3345	CP4896	CP3215	CP6751	CP7751	CP7040	CP7040
CP2888	CP2340	CP3385	CP3086	CP3638	CP2279	CP4145	CP2340	CP4909	CP3894	CP6752	CP7751	CP7041	CP7040
CP2889	CP2279	CP3386	CP3086	CP3639	CP2279	CP4152	CP2340	CP4910	CP3894	CP6760	CP5860	CP7045	CP7040
CP2890	CP2279	CP3387	CP3714	CP3645	CP2340	CP4155	CP4154	CP4915	CP3894	CP6761	CP7751	CP7060	CP7040
CP2895	CP2399	CP3390	CP2279	CP3646	CP2279	CP4156	CP4154	CP4920	CP3894	CP6771	CP7751	CP7600	CP7600
CP2910	CP2279	CP3394	CP2279	CP3647	CP2340	CP4158	CP4154	CP4921	CP3894	CP6778	CP5788	CP7601	CP7600
CP2917	CP2279	CP3395	CP2279	CP3650	CP2279	CP4166	CP4466	CP4922	CP3894	CP6789	CP5788	CP7602	CP7600
CP2918	CP2279	CP3416	CP2279	CP3666	CP3666	CP4169	CP4466	CP4930	CP3894	CP6800	CP4595	CP7603	CP7600
CP2919	CP2399	CP3417	CP2279	CP3667	CP3666	CP4176	CP4466	CP4960	CP4240	CP6805	CP7753	CP7605	CP7600
CP2935	CP2279	CP3426	CP2279	CP3668	CP3666	CP4177	CP4466	CP4970	CP4970	CP6806	CP7753	CP7606	CP7600
CP2936	CP2279	CP3428	CP2340	CP3676	CP2399	CP4190	CP3558	CP4974	CP4970	CP6810	CP4595	CP7607	CP7600
CP2937	CP2279	CP3434	CP3215	CP3677	CP2399	CP4218	CP3558	CP4979	CP4990	CP6820	CP5820	CP7609	CP7600
CP2966	CP2195	CP3435	CP3215	CP3679	CP3679	CP4219	CP3558	CP4995	CP4990	CP6828	CP6230	CP7611	CP7600
CP2986	CP2270	CP3436	CP2340	CP3685	CP2340	CP4220	CP2554	CP4996	CP3215	CP6830	CP2279	CP7751	CP7751
CP2988	CP2340	CP3438	CP2279	CP3687	CP2372	CP4226	CP4226						

FRICTION MATERIAL AVAILABILITY

In order to get the best performance from your AP Racing Brake System, it is important to choose the friction material which best suits the particular application.

AP Racing offer a large variety of the best friction materials currently available from various sources to suit every racing condition. The table on this page gives information on all the friction materials in the current range and their availability.

PAD ORDERING

1. Refer to caliper listing on the previous page to obtain the correct pad shape for a given caliper and check this against the pad shape illustrations on pages 62 to 65.
2. Consult the table opposite and select the material from those available referring to the information on pages 58 to 61 if necessary.
3. Example part number opposite. E.G. CP3894D54-RS42. This part number comprises 4 pads (1 axle set).
4. Construct part number as in the example below by adding the material suffix to the basic pad shape family number.

All pads with the following exceptions are sold in sets of 4.
 - CP4226, CP3086, CP4484, CP3386, CP2372, CP3666, CP4466 are in pairs (2 pads).

NB. For Carbon/Carbon Pad Material please contact AP Racing.

NB. Materials with the blackout segments are on phase out mode and once stocks have been exhausted will be made inactive

Friction Materials	Friction Material Availability																						
	AP Racing			Ferodo				Hawk	Mintex			Pagid		Raybestos			Others						
	APF 101	APF 102	APF 103	4003F	D52500	D53000	DS3000+	DS1.11	HT10	M1166	F1R	F2R	F4R	RS14	RS42	RS421	ST41	ST42	ST43	RQ3	APH420	SRR	
CP2195D38				•		•	•								•			•	•			•	
CP2279D42	•					•	•	•															
CP2279D50	•		•			•	•	•															
CP2340D38					•																		
CP2340D40						•							•										
CP2340D43				•	•	•				•	•	•						•					
CP2340D51					•	•				•	•	•			•	•							
CP2372D52						•																	
CP2399D43	•		•	•	•	•			•							•			•				
CP2702D53				•																			
CP2712D44				•																			
CP2749D66					•																		
CP2868D38																						•	
CP3086D37																						•	
CP3215D42	•		•			•	•	•			•	•					•			•			
CP3215D46	•		•	•	•	•	•	•				•					•			•			
CP3215D50	•		•	•	•	•	•	•			•	•				•			•				
CP3345D38				•	•	•						•			•	•							
CP3345D44	•		•	•	•	•		•						•	•			•	•				
CP3345D46									•														
CP3558D46										•													
CP3558D51												•											
CP3558D54	•		•			•	•	•				•											
CP3666D22																							•
CP3696D36																						•	
CP3714D54						•									•								
CP3894D46					•	•	•	•				•											
CP3894D51	•		•	•	•	•	•	•			•	•			•	•		•	•				
CP3894D54			•	•	•	•	•	•									•						
CP4226D27																					•	•	
CP4296D36						•																	
CP4296D43				•																			
CP4296D46						•									•								
CP4466D22						•															•		•
CP4479D50	•	•	•																				
CP4484D34						•															•		
CP4595D54	•		•			•	•		•			•											
CP4848D46	•		•			•		•									•						
CP5070D51				•	•											•							
CP5119D50				•					•				•		•								
CP5148D46	•		•			•	•	•				•											
CP5510D43			•			•	•					•											
CP5788D48	•		•					•				•											
CP5805D45						•					•	•											
CP5820D62	•		•			•	•				•	•											
CP5850D62	•		•			•	•				•	•											
CP6050D50						•																	
CP6070D43								•				•											
CP6070D49						•		•				•											
CP6210D46						•		•				•											
CP6210D54	•		•			•	•	•									•			•			
CP6230D54	•		•			•	•																
CP6600D55					•	•																	
CP6688D29																							•
CP7040D54						•	•																
CP7040D61						•	•																
CP7600D46					•	•						•											

EXAMPLE PAD PART NUMBER

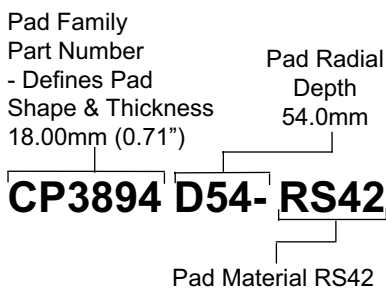

NOTES

BRAKE PAD PROFILES FOR AP RACING CALIPERS

The following details provide basic information for each of the pad shapes in the range of brake pads currently available from AP Racing. Please note that drawings are not to scale.

CP2195D38

- Pad Thickness = 10.5mm (0.40")
- Pad Depth = 38.4mm (1.51")
- Pad Area = 22.4cm² (3.47in²)

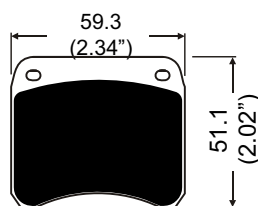
**CP2270D46**

- Pad Thickness = 16.6mm (0.65")
- Pad Depth = 46.0mm (1.81")
- Pad Area = 56.3cm² (8.27in²)

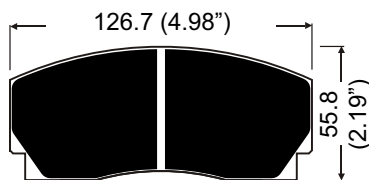
**CP2279D42**

- Pad Thickness = 20.4mm (0.80")
- Pad Depth = 42.0mm (1.65")
- Pad Area = 53.7cm² (8.38in²)

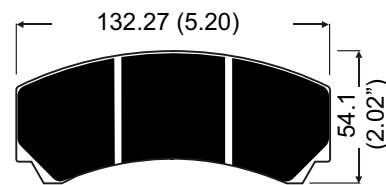
**CP2279D50**

- Pad Thickness = 20.4mm (0.80")
- Pad Depth = 50.3mm (1.98")
- Pad Area = 57.4cm² (8.89in²)

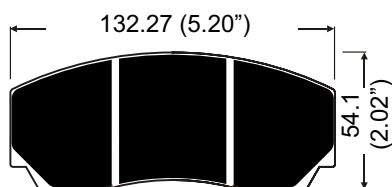
**CP2340D38**

- Pad Thickness = 15.9mm (0.63")
- Pad Depth = 38.0mm (1.50")
- Pad Area = 37.1cm² (5.75in²)

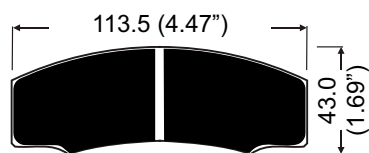
**CP2340D40**

- Pad Thickness = 15.9mm (0.63")
- Pad Depth = 40.0mm (1.57")
- Pad Area = 38.5cm² (5.96in²)

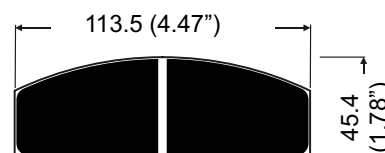
**CP2340D43**

- Pad Thickness = 15.9mm (0.63")
- Pad Depth = 43.1mm (1.70")
- Pad Area = 40.4cm² (6.26in²)

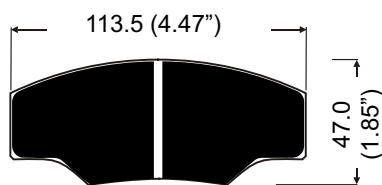
**CP2340D51**

- Pad Thickness = 15.9mm (0.63")
- Pad Depth = 50.8mm (2.0")
- Pad Area = 43.4cm² (6.73in²)

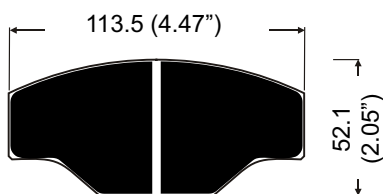
**CP2372D52**

- Pad Thickness = 15.9mm (0.63")
- Pad Depth = 52.3mm (2.06")
- Pad Area = 34.61cm² (5.36in²)

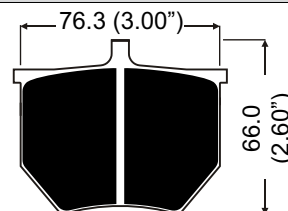
**CP2399D43**

- Pad Thickness = 14.3mm (0.56")
- Pad Depth = 43.0mm (1.69")
- Pad Area = 27.7cm² (4.29in²)

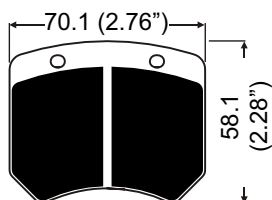
**CP2702D53**

- Pad Thickness = 18.0mm (0.70")
- Pad Depth = 53.3mm (2.09")
- Pad Area = 49.55cm² (7.68in²)

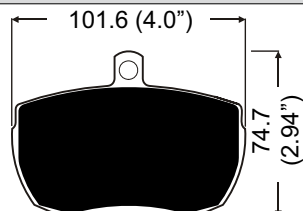
**CP2712D44**

- Pad Thickness = 14.8mm (0.58")
- Pad Depth = 43.5mm (1.71")
- Pad Area = 25.39cm² (3.93in²)

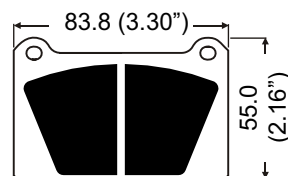
**CP2749D66**

- Pad Thickness = 25.0mm (0.98")
- Pad Depth = 65.5mm (2.58")
- Pad Area = 77.84cm² (12.06in²)

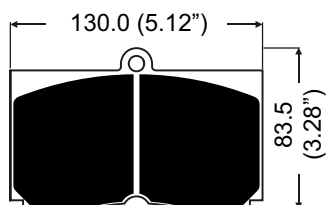
**CP2868D38**

- Pad Thickness = 6.95mm (0.27")
- Pad Depth = 38.4mm (1.51")
- Pad Area = 22.4cm² (3.47in²)

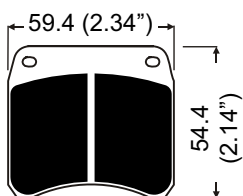
**CP3086D37**

- Pad Thickness = 8.0mm (0.31")
- Pad Depth = 37.0mm (1.45")
- Pad Area = 26.13cm² (4.05in²)

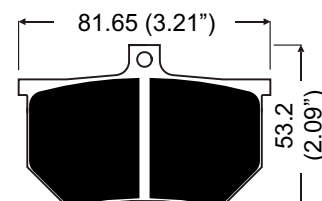

BRAKE PAD PROFILES FOR AP RACING CALIPERS

The following details provide basic information for each of the pad shapes in the range of brake pads currently available from AP Racing. Please note that drawings are not to scale.

CP3215D42
 - Pad Thickness = 16.75mm (0.66")
 - Pad Depth = 42.2mm (1.66")
 - Pad Area = 51.9cm² (8.04in²)

CP3215D46
 - Pad Thickness = 16.75mm (0.66")
 - Pad Depth = 45.67mm (1.79")
 - Pad Area = 54.6cm² (8.45in²)

CP3215D50
 - Pad Thickness = 16.75mm (0.66")
 - Pad Depth = 50.29mm (1.98")
 - Pad Area = 57.36cm² (8.89in²)

CP3345D38
 - Pad Thickness = 15.9mm (0.66")
 - Pad Depth = 38.0mm (1.49")
 - Pad Area = 40.4cm² (6.26in²)

CP3345D44
 - Pad Thickness = 15.9mm (0.66")
 - Pad Depth = 44.14mm (1.74")
 - Pad Area = 43.47cm² (6.73in²)

CP3558D46
 - Pad Thickness = 25.0mm (0.98")
 - Pad Depth = 45.7mm (1.80")
 - Pad Area = 66.6cm² (10.32in²)

CP3558D51
 - Pad Thickness = 25.0mm (0.98")
 - Pad Depth = 50.8mm (2.00")
 - Pad Area = 73.7cm² (11.43in²)

CP3558D54
 - Pad Thickness = 25.0mm (0.98")
 - Pad Depth = 54.0mm (2.12")
 - Pad Area = 77.43cm² (12.00in²)

CP3666D22
 - Pad Thickness = 8.9mm (0.35")
 - Pad Depth = 22.0mm (0.86")
 - Pad Area = 19.83cm² (3.07in²)

CP3714D54
 - Pad Thickness = 25.0mm (0.98")
 - Pad Depth = 54.0mm (2.12")
 - Pad Area = 66.02cm² (10.23in²)

CP3894D46
 - Pad Thickness = 18.0mm (0.71")
 - Pad Depth = 45.7mm (1.80")
 - Pad Area = 66.6cm² (10.32in²)

CP3894D51
 - Pad Thickness = 18.0mm (0.71")
 - Pad Depth = 50.8mm (2.00")
 - Pad Area = 73.7cm² (11.43in²)

CP3894D54
 - Pad Thickness = 18.0mm (0.71")
 - Pad Depth = 54.0mm (2.12")
 - Pad Area = 77.44cm² (12.00in²)

CP4226D27
 - Pad Thickness = 7.0mm (0.27")
 - Pad Depth = 26.84mm (1.05")
 - Pad Area = 9.4cm² (1.45in²)

CP4296D43
 - Pad Thickness = 16.0mm (0.63")
 - Pad Depth = 43.3mm (1.70")
 - Pad Area = 35.9cm² (5.56in²)

BRAKE PAD PROFILES FOR AP RACING CALIPERS

The following details provide basic information for each of the pad shapes in the range of brake pads currently available from AP Racing. Please note that drawings are not to scale.

CP4296D46

- Pad Thickness = 16.0mm (0.63")
- Pad Depth = 45.7mm (1.79")
- Pad Area = 36.9cm² (5.72in²)

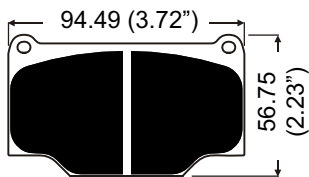
**CP4466D22**

- Pad Thickness = 9.0mm (0.35")
- Pad Depth = 22.0mm (0.86")
- Pad Area = 19.83cm² (3.07in²)

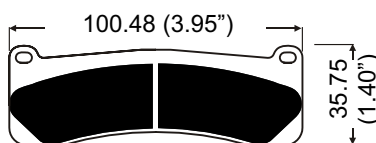
**CP4479D50**

- Pad Thickness = 25.0mm (0.31")
- Pad Depth = 50.3mm (1.98")
- Pad Area = 60.44cm² (9.36in²)

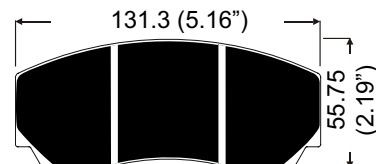
**CP4484D34**

- Pad Thickness = 8.0mm (0.31")
- Pad Depth = 34.0mm (1.34")
- Pad Area = 24.14cm² (3.74in²)

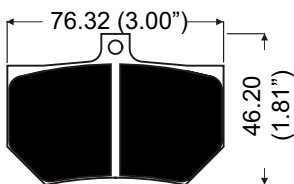
**CP4595D54**

- Pad Thickness = 28.5mm (1.12")
- Pad Depth = 54.0mm (2.12")
- Pad Area = 77.44cm² (12.00in²)

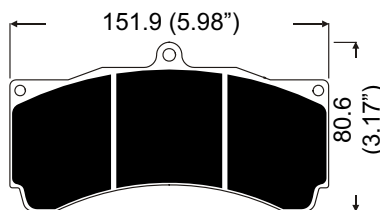
**CP4848D46**

- Pad Thickness = 18.0mm (0.70")
- Pad Depth = 46.0mm (1.81")
- Pad Area = 35.5cm² (5.50in²)

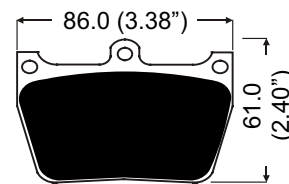
**CP5045D61**

- Pad Thickness = 24.0mm (0.94")
- Pad Depth = 60.5mm (2.38")
- Pad Area = 74.0cm² (11.47in²)

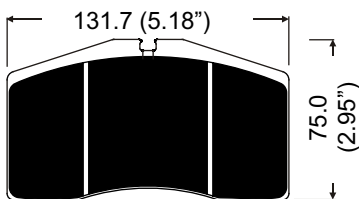
**CP5070D51**

- Pad Thickness = 17.0mm (0.67")
- Pad Depth = 51.5mm (2.02")
- Pad Area = 77.2cm² (11.96in²)

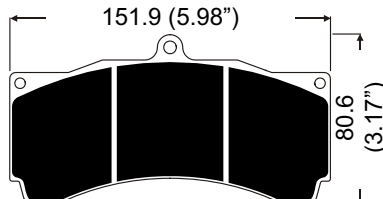
**CP5119D50**

- Pad Thickness = 14.35mm (0.56")
- Pad Depth = 50.0mm (1.96")
- Pad Area = 33.70cm² (5.22in²)

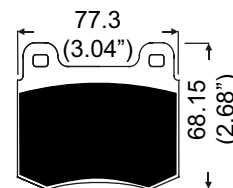
**CP5148D46**

- Pad Thickness = 15.0mm (0.59")
- Pad Depth = 46.0mm (1.81")
- Pad Area = 35.5cm² (5.50in²)

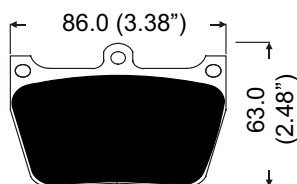
**CP5510D43**

- Pad Thickness = 20.0mm (0.78")
- Pad Depth = 43.0mm (1.69")
- Pad Area = 39.39cm² (6.10in²)

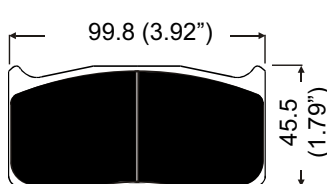
**CP5788D48**

- Pad Thickness = 20.0mm (0.78")
- Pad Depth = 48.0mm (1.88")
- Pad Area = 63.2cm² (9.79in²)

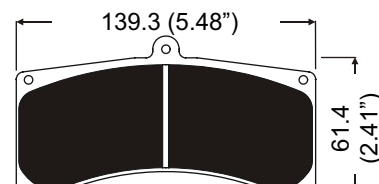
**CP5805D45**

- Pad Thickness = 19.8mm (0.77")
- Pad Depth = 45.0mm (1.77")
- Pad Area = 68.07cm² (10.55in²)

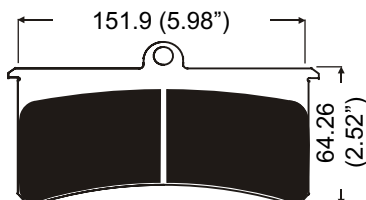
**CP5820D62**

- Pad Thickness = 29.8mm (1.17")
- Pad Depth = 62.0mm (2.44")
- Pad Area = 89.84cm² (13.78in²)

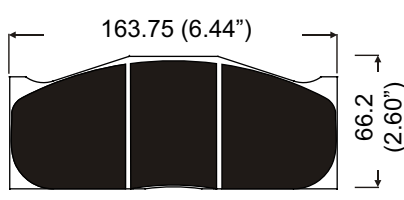
**CP5850D62**

- Pad Thickness = 27.7mm (1.09")
- Pad Depth = 62.0mm (2.44")
- Pad Area = 78.88cm² (12.22in²)

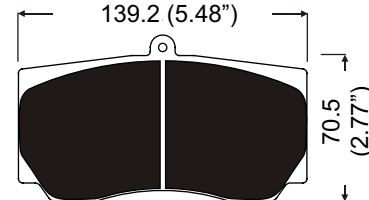

BRAKE PAD PROFILES FOR AP RACING CALIPERS

The following details provide basic information for each of the pad shapes in the range of brake pads currently available from AP Racing. Please note that drawings are not to scale.

CP6050D50
 - Pad Thickness = 20.0mm (0.78")
 - Pad Depth = 50.0mm (1.96")
 - Pad Area = 38.8cm² (6.01in²)

CP6070D49
 - Pad Thickness = 25.0mm (0.98")
 - Pad Depth = 49.0mm (1.92")
 - Pad Area = 61.6cm² (9.54in²)

CP6210D54
 - Pad Thickness = 30.0mm (1.18")
 - Pad Depth = 54.0mm (2.12")
 - Pad Area = 83.07cm² (12.97in²)

CP6230D54
 - Pad Thickness = 25.0mm (0.98")
 - Pad Depth = 54.0mm (2.12")
 - Pad Area = 81.62cm² (12.65in²)

CP6600D55
 - Pad Thickness = 16.75mm (0.66")
 - Pad Depth = 55.0mm (2.16")
 - Pad Area = 64.6cm² (10.01in²)

CP6688D29
 - Pad Thickness = 10.0mm (0.39")
 - Pad Depth = 28.5mm (1.12")
 - Pad Area = 11.09cm² (1.71in²)

CP7040D54
 - Pad Thickness = 16.75mm (0.66")
 - Pad Depth = 54.0mm (2.12")
 - Pad Area = 68.35cm² (10.59in²)

CP7040D61
 - Pad Thickness = 16.75mm (0.66")
 - Pad Depth = 61.0mm (2.40")
 - Pad Area = 72.5cm² (11.23in²)

CP7600D43
 - Pad Thickness = 16.0mm (0.63")
 - Pad Depth = 43.0mm (1.69")
 - Pad Area = 42.2cm² (6.54in²)

CP7600D46
 - Pad Thickness = 16.0mm (0.63")
 - Pad Depth = 46.2mm (1.81")
 - Pad Area = 43.5cm² (6.74in²)

NOTES



ACTUATION

It is now widely understood that the actuation system is a major factor in the overall performance of the brake system. AP Racing R&D is now focused on this area and a number of new products have been added to the range which now includes not only Master Cylinders, Brake Fluid, Reservoirs, Proportioning Valves but also Floor Mounted and Underslung Pedal Boxes, Balance Bars, and accessories. This Section provides technical information regarding each product, if you require further details please contact AP Racing Technical Dept

MASTER CYLINDERS

AP Racing Master Cylinders have been developed with the benefit of our unparalleled experience in racing brake technology to respond to the severe demands encountered under competition conditions and are used in motorsport from F1 to Rally to Saloon Cars. The Current range of lightweight aluminium alloy master cylinders comprises 8 designs suitable for all forms of competition use. Each master cylinder is individually shimmed during manufacture to give a shorter cut off and less lost travel than equivalent production cylinders and have 3 bypass ports for faster fluid return. The standard short cut-off (0.68mm to 1.09mm / 0.027" to 0.043") cylinders should be used for most normal applications and especially where rapid fluid return when changing pads is required. Extra short cut-off (0.48mm to 0.63mm / 0.019" to 0.025") cylinders are available in most styles and are identified with an 'E' suffix: e.g. CP2623-92PRT115E. Most designs are available in 10 bore sizes from 14mm to 25.4 (1.00") diameter. Below and opposite is a brief description of each master cylinder within the range.

MASTER CYLINDER RANGE

CP2623 - A compact flanged mounted Master Cylinder suitable for all brake and clutch applications especially where space is restricted. Short travel to cut off is standard, extra short cut-off also available. 10 bore sizes from 14.0mm to 25.4mm. Hydraulic threads are Imperial.



CP4623 - A compact Master Cylinder similar to CP2623 but with a 60°



mounting flange offset to give improved access to mounting bolts. Short travel to cut-off is standard with extra short cut-off available to order. 10 bore sizes from 14.0mm to 25.4mm. All threads on this master cylinder are metric.



CP5623 - A compact Master Cylinder based on CP2623 but with metric hydraulic ports. 9 bore sizes from 14.0mm to 25.4mm.

CP6093 - A Master Cylinder suitable for most brake and clutch applications



where space restrictions are not a primary consideration. The longer available stroke makes it particularly suitable for some clutch installations. Long thread portion allows the push rod length to be cut to suit. 8 bore sizes from 15.9mm to 25.4mm Supercedes CP2293 Master Cylinder family



CP4400 - A compact Master Cylinder which has been specially designed with a 'centre lock' bulkhead fixing (10mm Min. / 22mm Max. thick) to meet the installation requirements of composite structure racing cars. The inlet and the outlet ports are positioned at the end of the master cylinder away from the bulkhead, to provide clearance for steering racks etc., where required. Extra short travel to cut off, reducing the amount of lost pedal travel, is standard on this cylinder with short cut-off available to order where rapid fluid return is required. 9 bore sizes from 14.0mm to 15/16". Hydraulic threads are imperial.

CP5854 - A new high efficiency single circuit, short push type master cylinder. Fixed



through a trunnion system running in needle roller bearings and with a one piece piston / push rod it offers a significant improvement in efficiency over traditional master cylinder designs. Full range of 10 bore sizes. Imperial threads.



CP5855 - A new high efficiency single circuit, short push type master cylinder. Fixed through a spherical bearing and with a one piece piston / push rod it offers a significant improvement in efficiency over

traditional master cylinder designs. Full range of 10 bore sizes. Imperial threads. Replaces CP5511 and CP4411.

CP6465 - A new concept in Master Cylinder design.



This cylinder operates on the Pull rather than Push principle of other cylinders. It has a built in trunnion mounted in needle roller bearings for direct mounting to the balance bar. The ultimate in master cylinder efficiency. Metric threads.

IMPORTANT NOTE:-

AP Racing master cylinders are individually shimmed during assembly to minimise lost travel therefore push rods, pistons and other internal components must never be switched between individual master cylinders.

ENDURANCE RACING

In races where pad changes may be required short cut-off versions should be selected in preference to extra short cut-off. These assemblies allow fluid to be forced back into the reservoir more rapidly during pad changes.

NON CAPTIVE PUSH RODS



Special versions of some master cylinders are available with 'non captive' push rods for use where rapid master cylinder changes may be required during an event (e.g. rally stages). Push rods to suit these master cylinders must be ordered separately under the following part numbers.

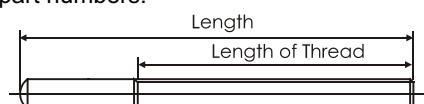

Push Rod Part No.	Length.	Thread Form.	Thread Length.
CP2142-45	112.0mm	5/16" UNF	60.0mm
CP2142-47	157.0mm	5/16" UNF	105.0mm
CP2142-48	157.0mm	M8x1.25	105.0mm

IDENTIFICATION OF BORE SIZES.

All AP Racing master cylinders have their part number, nominal bore sizes laser marked on the body together with batch codes, this allows full manufacturing traceability. All master cylinders also have a coloured tie wrapped around the body for quick visual identification of bore size.

14.0mm (0.551") 0.55"	Black & Orange.
15.0mm (0.590") 0.60"	Black & Red.
15.9mm (0.625") 5/8"	Black.
16.8mm (0.661") 0.66"	Black & Yellow.
17.8mm (0.70") 0.7"	Blue.
19.1mm (0.75") 3/4"	Green.
20.6mm (0.812") 13/16"	Orange.
22.2mm (0.875") 7/8"	Red.
23.8mm (0.937") 15/16"	White.
25.4mm (1.00") 1"	Yellow.

ORDERING

When ordering please quote the full part number whenever possible. Part numbers are given in the individual master cylinder pages. An explanation of the part numbers is given below.

Master Cylinder Family Number Push Rod Thread Form (M8 x 1.25)

CP4623-90PRM160E

Bore Size Push Rod Length 'E' Denotes Short Cut-Off Version
 Ø15.9mm (5/8") 160mm (6.30")

NB. For non captive push rod version add 'NC' after bore size e.g. CP4623-90NCE

MASTER CYLINDER REPAIR KITS

CP2623, CP4400, CP4623, CP5623 and CP6093.

Repair kit information for CP2623, CP4400, CP4623, CP5623 and CP6093 are tabled below for all Master Cylinders sizes. Please follow the instructions below.

INSTRUCTIONS

1) Remove rubber boot (11) and circlip (10). 2) Carefully remove internal components. 3) Replace the following. (Making sure all seals have been lubricated with Brake Fluid). Primary seal (4), Piston Washer (5) and the Secondary seal (7). (Care must be taken when assembling seals as damage may be caused) 4) Check bore is free from debris. 5) Lubricate bore with Brake Fluid. 6) Reassemble internal components into body. 7) Use new circlip (10) to secure internal components and new boot to protect from debris (11).

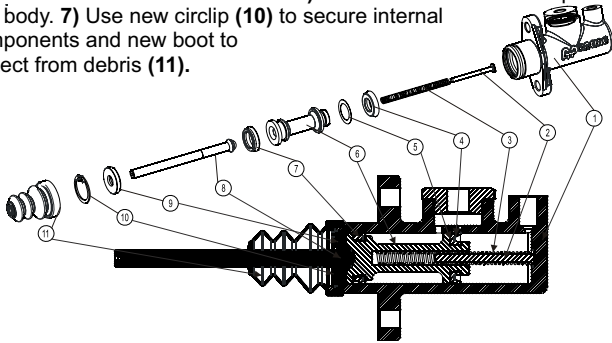

Ref.	Description.	Included in Repair Kit.	Bore Size.	Repair Kit Part No.
1.	Body.		14.00mm	CP2623-88RK
2.	Spring Guide Pin.		15.00mm	CP2623-89RK
3.	MCyl Return spring.		15.9mm (0.625") 5/8"	CP2623-90RK
4.	Primary Seal.	Yes.	16.8mm	CP2623-905RK
5.	Piston Washer.	Yes.	17.8mm (0.70")	CP2623-91RK
6.	Piston		19.1mm (0.75") 3/4"	CP2623-92RK
7.	Secondary Seal.	Yes.	20.6mm (0.812") 13/16"	CP2623-93RK
8.	Push Rod.		22.2mm (0.875") 7/8"	CP2623-94RK
9.	Piston Stop Washer.		23.8mm (0.937") 15/16"	CP2623-95RK
10.	Circlip.	Yes.		
11.	Boot.	Yes.	25.4mm (1.00")	CP2623-96RK

CP5854 and CP5855.

Repair kit information for CP5854 and CP5855 are tabled opposite for all Master Cylinders bore sizes. Please follow the instructions given.

INSTRUCTIONS

1) Remove rubber boot (11) and circlip (13). 2) Carefully remove internal components. 3) Replace the following. (Making sure all seals have been lubricated with Brake Fluid). Primary seal (1), Slydring Bearing (2), Piston Washer (4), O-Ring Piston Seal (5) & O-Ring End Cap Seal (9). (Care must be taken when assembling seals as damage may be caused). 4) Check bore is free from debris. 5) Lubricate bore with Brake Fluid. 6) Reassemble internal components into body. 7) Use new circlip (13) to secure internal components and new boot to protect from debris (11).

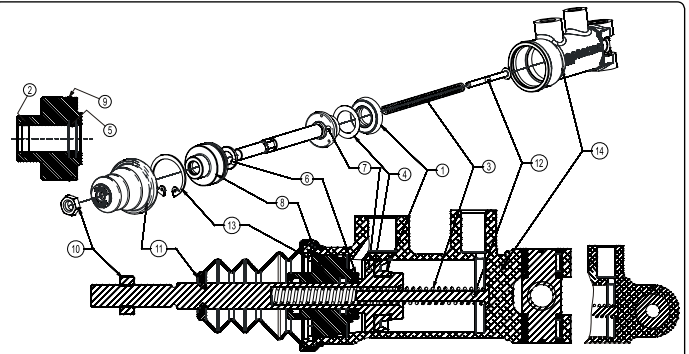

Ref.	Description.	Included in Repair Kit.	Bore Size.	Repair Kit Part No.
1.	Primary Seal.	Yes.	14.00mm	CP5854-88RK
2.	Slydring Bearing.	Yes.	15.00mm	CP5854-89RK
3.	MCyl Return Spring.		15.9mm (0.625") 5/8"	CP5854-90RK
4.	Piston Washer.	Yes.	16.8mm	CP5854-905RK
5.	O-Ring Piston Seal.	Yes.	17.8mm (0.70")	CP5854-91RK
6.	Cut-off Shim.			
7.	Piston.		19.1mm (0.75") 3/4"	CP5854-92RK
8.	End Cap.			
9.	O-Ring Cap Seal.	Yes.	20.6mm (0.812") 13/16"	CP5854-93RK
10.	Lock Nut 5/16" UNF.		22.2mm (0.875") 7/8"	CP5854-94RK
11.	Boot.	Yes.		
12.	Spring Guide Pin.		23.8mm (0.937") 15/16"	CP5854-95RK
13.	Circlip.	Yes.		
14.	Body.		25.4mm (1.00")	CP5854-96RK

CP6465.

Repair kit information for CP6465 are tabled below for all Master Cylinders bore sizes. Please follow the instructions given.

INSTRUCTIONS

1) Remove rubber boot (12) and un screw end cap (9). 2) Carefully remove internal components. 3) Replace the following. (Making sure all seals have been lubricated with Brake Fluid). Primary seal (1), Slydring Bearing (2), Piston Washer (4), O-Ring Piston Seal (5) & O-Ring End Cap Seal (8). (Care must be taken when assembling seals as damage may be caused) 4) Check bore is free from debris. 5) Lubricate bore with Brake Fluid. 6) Reassemble internal components into body. 7) Use original end cap (9) to secure internal components. Tighten to 24Nm (18lbf-ft) and use loctite threadlocker 242 or 243). 8) Fit new boot (12) to protect from debris.

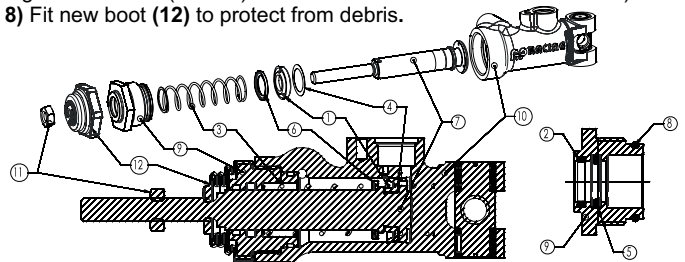

Ref.	Description.	Included in Repair Kit.	Bore Size.	Repair Kit Part No.
1.	Primary Cup Seal.	Yes.	14.9mm	CP6465-149RK
2.	Slydring Bearing.	Yes.	16.2mm	CP6465-162RK
3.	MCyl Return spring.		17.3mm	CP6465-173RK
4.	Piston Washer.	Yes.	18.8mm	CP6465-188RK
5.	O-Ring Piston Seal.	Yes.	20.2mm	CP6465-202RK
6.	Piston Stop.		21.8mm	CP6465-218RK
7.	Piston.		23.7mm	CP6465-237RK
8.	O-Ring Cap Seal.	Yes.	25.4mm	CP6465-254RK
9.	End Cap.			
10.	Body.			
11.	Locknut M8x1.25			
12.	Boot.			

IMPORTANT NOTE

The changing of internal components of the master cylinder in rare cases, may alter the distance to cut-off. If you are unable to bleed the cylinder after a seal change, please consult AP Racing. Also ensure that any parts that have been disassembled are kept with the original cylinder and are not mixed.

CP2623



GENERAL INFORMATION

- A compact Master Cylinder suitable for all brake and clutch applications especially where space is restricted.
- Short travel to cut-off standard.
- Aluminium alloy body.
- Flange mounting.
- Non captive cylinders available.
- Extra short Cut-Off option available.
- Replaces CP3823 Master Cylinder family.

TECHNICAL DETAILS.

Weight.	0.31kg (0.7lbs)
Full Stroke.	25.4mm (1.00")
Travel To Cut-Off.	
- Short	0.68 to 1.09mm (.027" to .043")
- Extra Short	0.48 to 0.63mm (.019" to .025")
Hydraulic Thread.	
- Outlet.	3/8" x 24UNF
- Inlet.	7/16" x 20UNF
Push Rod Threads.	
- PRM	M8 x 1.25
- PRT	5/16" UNF
Push Rod Length From Mounting Flange.	
PRM/PRT115	115mm (4.53")
PRM/PRT160	160mm (6.30")

PART NUMBERS

Bore Sizes.	Short Cut-off Cylinders.		Non Captive Cylinders.
	PRM Pushrod.	PRT Pushrod.	
14.0mm.	CP2623-88PRM115 CP2623-88PRM160	CP2623-88PRT115 CP2623-88PRT160	CP2623-88NC
15.0mm.	CP2623-89PRM115 CP2623-89PRM160	CP2623-89PRT115 CP2623-89PRT160	CP2623-89NC
15.9mm (.625") 5/8"	CP2623-90PRM115 CP2623-90PRM160	CP2623-90PRT115 CP2623-90PRT160	CP2623-90NC
16.8mm	CP2623-905PRM115 CP2623-905PRM160	CP2623-905PRT115 CP2623-905PRT160	CP2623-905NC
17.8 (.70")	CP2623-91PRM115 CP2623-91PRM160	CP2623-91PRT115 CP2623-91PRT160	CP2623-91NC
19.1mm (.75") 3/4"	CP2623-92PRM115 CP2623-92PRM160	CP2623-92PRT115 CP2623-92PRT160	CP2623-92NC
20.6mm (.812") 13/16"	CP2623-93PRM115 CP2623-93PRM160	CP2623-93PRT115 CP2623-93PRT160	CP2623-93NC
22.2mm (.875") 7/8"	CP2623-94PRM115 CP2623-94PRM160	CP2623-94PRT115 CP2623-94PRT160	CP2623-94NC
23.8mm (.937") 15/16"	CP2623-95PRM115 CP2623-95PRM160	CP2623-95PRT115 CP2623-95PRT160	CP2623-95NC
25.4mm (1.00").	CP2623-96PRM115 CP2623-96PRM160	CP2623-96PRT115 CP2623-96PRT160	CP2623-96NC

- Ordering -

Select the required the required cylinder from the part numbers above.
E.G. CP2623-94PRM115.

- Extra Short Cut-Off Cylinder -

For Extra short cut-off, add 'E' suffix to the end of Part Number.
E.G. CP2623-94PRT115E.

INSTALLATION DRAWING

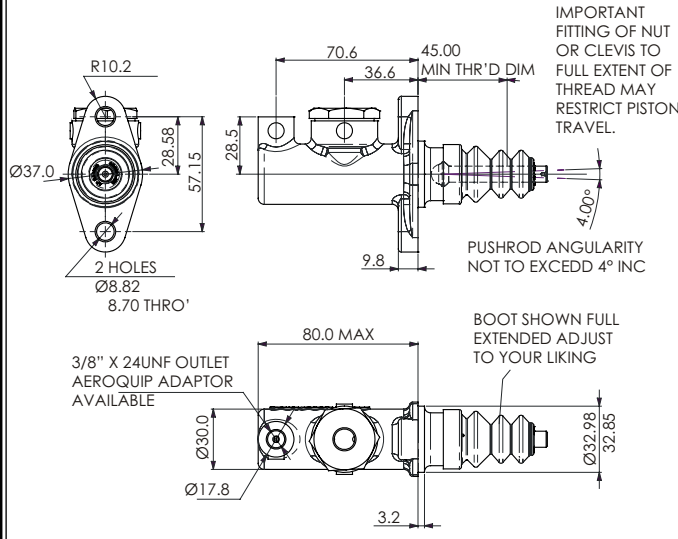

CP4623



GENERAL INFORMATION

- A compact Master Cylinder similar to CP2623 but with a 60° mounting flange offset to give improved access to mounting bolts.
- Extra short travel to cut off standard.
- Short travel to cut-off optional.
- Aluminium Alloy body.
- 60° Flange mounting.
- Non captive cylinders available.
- All threads on this master cylinder are metric.

TECHNICAL DETAILS.

Weight.	0.31kg (0.7lbs)
Full Stroke.	25.4mm (1.00")
Travel To Cut-Off.	
- Extra Short	0.48 to 0.63mm (.019" to .025")
Hydraulic Thread.	
- Outlet.	M10 x 1.0
- Inlet.	M12 x 1.0
Push Rod Threads.	
- PRM	M8 x 1.25
- PRT	5/16" UNF
Push Rod Length From Mounting Flange.	
PRM/PRT115	115mm (4.53")
PRM/PRT160	160mm (6.30")

PART NUMBERS

Bore Sizes.	Extra Short Cut-off Cylinders.		Non Captive Cylinders.
	PRM Pushrod.	PRT Pushrod.	
14.0mm.	CP4623-88PRM115 CP4623-88PRM160	CP4623-88PRT115 CP4623-88PRT160	CP4623-88NC
15.0mm.	CP4623-89PRM115 CP4623-89PRM160	CP4623-89PRT115 CP4623-89PRT160	CP4623-89NC
15.9mm (.625") 5/8"	CP4623-90PRM115 CP4623-90PRM160	CP4623-90PRT115 CP4623-90PRT160	CP4623-90NC
16.8mm	CP4623-905PRM115 CP4623-905PRM160	CP4623-905PRT115 CP4623-905PRT160	CP4623-905NC
17.8 (.70")	CP4623-91PRM115 CP4623-91PRM160	CP4623-91PRT115 CP4623-91PRT160	CP4623-91NC
19.1mm (.75") 3/4"	CP4623-92PRM115 CP4623-92PRM160	CP4623-92PRT115 CP4623-92PRT160	CP4623-92NC
20.6mm (.812") 13/16"	CP4623-93PRM115 CP4623-93PRM160	CP4623-93PRT115 CP4623-93PRT160	CP4623-93NC
22.2mm (.875") 7/8"	CP4623-94PRM115 CP4623-94PRM160	CP4623-94PRT115 CP4623-94PRT160	CP4623-94NC
23.8mm (.937") 15/16"	CP4623-95PRM115 CP4623-95PRM160	CP4623-95PRT115 CP4623-95PRT160	CP4623-95NC
25.4mm (1.00").	CP4623-96PRM115 CP4623-96PRM160	CP4623-96PRT115 CP4623-96PRT160	CP4623-96NC

- Ordering -

Select the required the required cylinder from the part numbers above.
E.G. CP4623-94PRM115E.

- Short Cut-Off Cylinder Option -

For Short cut-off, Remove 'E' suffix from the end of Part Number.
E.G. CP4623-94PRT115.

INSTALLATION DRAWING

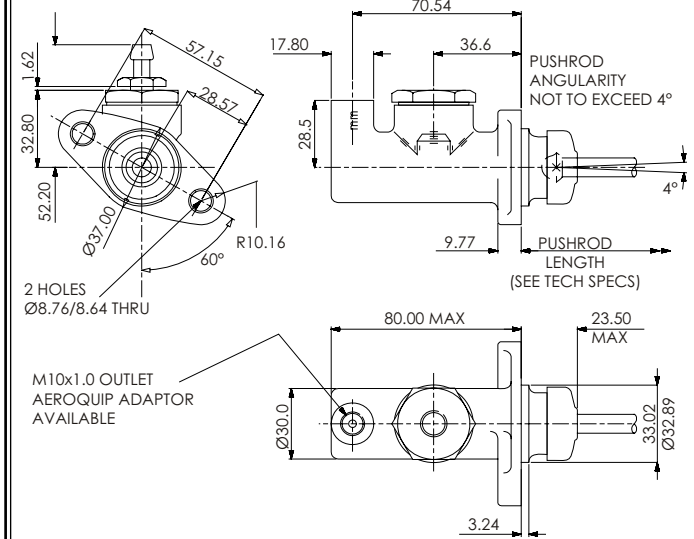

CP5855

GENERAL INFORMATION

- Aluminium alloy body.
- Compact design.
- Hard anodised.
- High efficiency push type design.
- Mounted through a spherical bearing.
- One piece piston and push rod.
- Full range of 10 bore sizes.
- Extra short travel to cut-off standard.
- Rubber boots fitted as standard.
- Version with built in trunnion mounting available under Part No. CP5854 Family.
- Replaces CP5511 and CP4411 families.



TECHNICAL DETAILS.

Weight.	0.28 to 0.293kg (0.61 to 0.64lbs)
Full Stroke.	
14mm to 7/8" Bores	30.0mm (1.18")
15/16" to 1.00" Bores	28.0mm (1.10")
Travel To Cut-Off.	
- Extra Short	0.48 to 0.63mm (.019" to .025")
Hydraulic Thread.	
- Outlet.	3/8" x 24UNF
- Inlet.	7/16" x 20UNF
Push Rod Threads.	
- PRTE	5/16" x 24 UNF

PART NUMBERS

Bore Sizes.	Extra Short Cut-off Cylinders.	Repair Kit.	Dia 'A' (mm)
14.0mm.	CP5855-88PRTE	CP5854-88RK	22.92 on drawing
15.0mm.	CP5855-89PRTE	CP5854-89RK	
15.9mm (.625") 5/8"	CP5855-90PRTE	CP5854-90RK	
16.8mm	CP5855-905PRTE	CP5854-905RK	
17.8 (.70")	CP5855-91PRTE	CP5854-91RK	
19.1mm (.75") 3/4"	CP5855-92PRTE	CP5854-92RK	
20.6mm (.812") 13/16"	CP5855-93PRTE	CP5854-93RK	29.25 on drawing
22.2mm (.875") 7/8"	CP5855-94PRTE	CP5854-94RK	
23.8mm (.937") 15/16"	CP5855-95PRTE	CP5854-95RK	
25.4mm (1.00").	CP5855-96PRTE	CP5854-96RK	

- Ordering -

Select the required bore size from the table above.
E.G. CP5855-94PRTE.

INSTALLATION DRAWING

FLATS ARE INCLUDED ON PISTON TO HELP ASSEMBLE THE CYLINDER INTO A PEDAL BOX

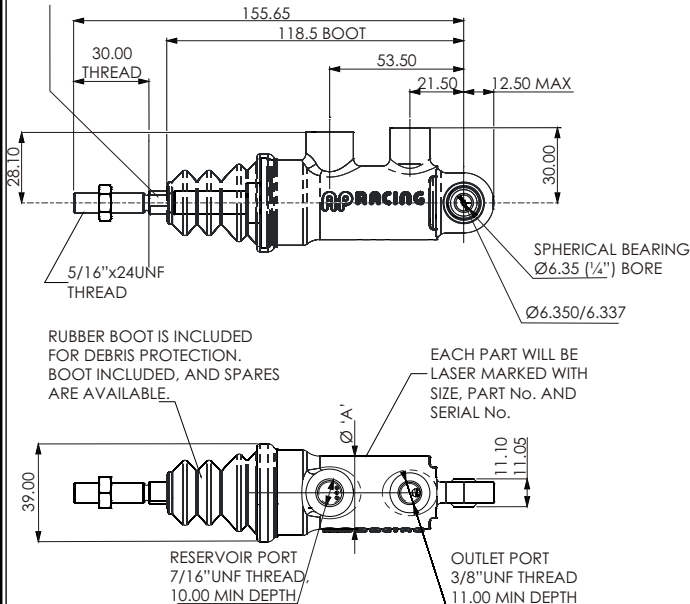

CP6465

GENERAL INFORMATION

- A new concept pull type design, more efficient than conventional type master cylinders.
- Aluminium Alloy Body.
- Has a built in trunnion mounted in needle roller bearing for direct mounting to the balance bar.
- Low profile inlet and outlet.
- Special "plug in" inlet connection can be swaged directly to dash 4 hose.
- Use with CP5520-2 or CP5516-17 type trunnion type balance bar or purpose designed pedal box.
- Choice of 8 bore sizes.
- Extra short travel to cut-off standard.



TECHNICAL DETAILS.

Weight.	0.23 to 0.27kg (0.51 to 0.59lbs)
Full Stroke.	25.4mm (1.00")
Travel To Cut-Off.	
- Extra Short	0.48 to 0.63mm (.019" to .025")
Hydraulic Thread.	
- Outlet.	M10 x 1.0
Inlet, Special Fittings.	
75° type.	CP6465-10
Straight type.	CP6465-11
90° type.	CP6465-12
All inlet fittings are sold separately.	
Push Rod Threads.	
- PRME	M8 x 1.25

PART NUMBERS

Bore Sizes.	Extra Short Cut-off Cylinders.	Repair Kits.
	PRME Pushrod.	
14.9mm (.587").	CP6465-149PRME	CP6465-149RK
16.2mm (.368").	CP6465-162PRME	CP6465-162RK
17.3 (.681").	CP6465-173PRME	CP6465-173RK
18.8mm (.740").	CP6465-188PRME	CP6465-188RK
20.2mm (.795").	CP6465-202PRME	CP6465-202RK
21.8mm (.858").	CP6465-218PRME	CP6465-218RK
23.7mm (.933").	CP6465-237PRME	CP6465-237RK
25.4mm (1.00").	CP6465-254PRME	CP6465-254RK

- Ordering -

Select the required bore size from the table above.
E.G. CP6465-237PRME.

INSTALLATION DRAWING

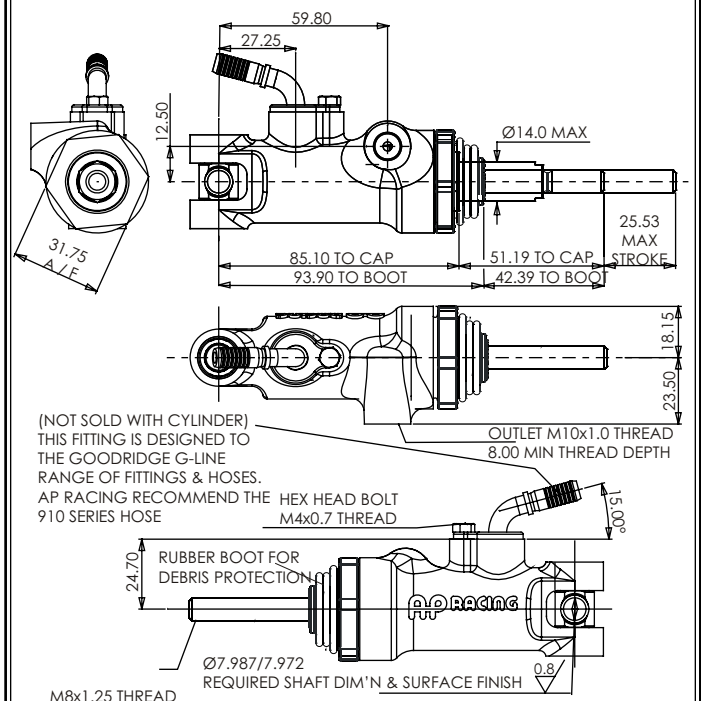

CP6026

New Product

GENERAL INFORMATION

- Double ended hand brake Master Cylinder.
- For use with dual circuits.
- Where diagonal brake split is mandatory.
- Forged Aluminium alloy body.
- Lightweight compact design.
- Hard anodised.
- High efficiency push type design.
- Mounted using rod ended spherical bearings.
- One piece piston and push rod.
- Rubber boots fitted as standard.



TECHNICAL DETAILS.

Weight.	0.25kg (0.55lbs)
Full Stroke.	2 x 12mm
Bore Dia.	0.70" (17.8mm)
Travel To Cut-Off.	
- Extra Short	0.48 to 0.63mm (.019" to .025")
Hydraulic Thread.	
- Outlet.	M10 x 1.0
- Inlet.	M10 x 1.0
Typical Application.	Dual Circuit hand brake systems.

PART NUMBERS & SPARES

PART NUMBER = CP6026-91

SPARES LIST

REF:	DESCRIPTION	AP RACING PART No.	QTY/ CYL
1	ROD END	CP6026-101	2
2	M6 NUT	ME21001	2

ADDITIONAL SPARE PARTS

-	SEAL REPAIR KIT (2 OFF EACH PART) BOOTS, SEALS, PISTON WASHERS & CIRCLIPS.	CP6025-91RK	-
---	--	-------------	---

INSTALLATION DRAWING

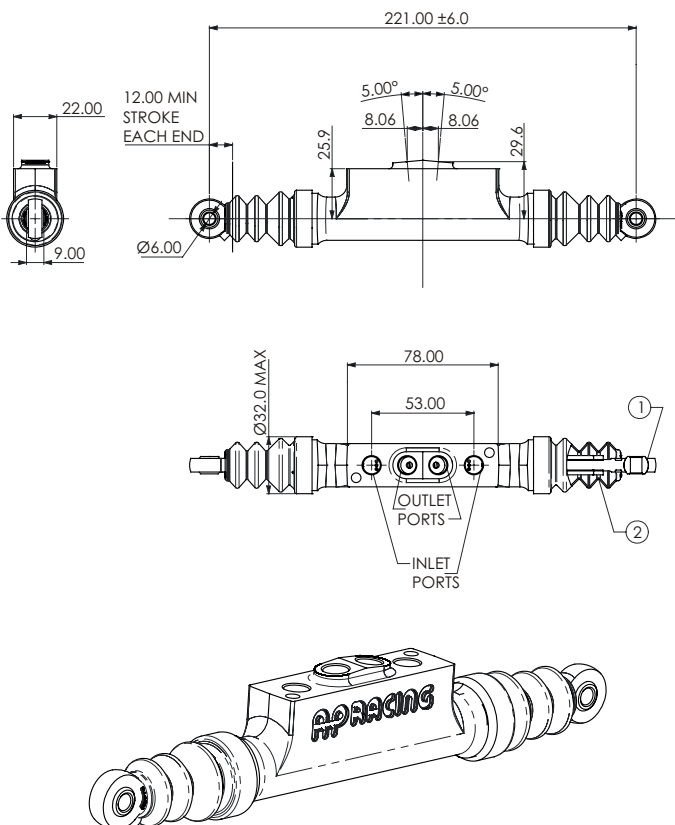

NOTES.



INTRODUCTION

AP Racing offer a comprehensive range of plastic reservoir to compliment not only are Master Cylinders but other manufacturers also.

RESERVOIR RANGE

CP4709 TYPE

A small diameter plastic reservoir with central outlet which can be screwed directly into a master cylinder.

- Available in a choice of 3 volumes.
- 'O' Ring seal supplied.
- CP2709-156 Bellows available.
- Push on connector for remote cylinder available - CP4709-107.

Part Numbers

- CP4709-10, -11 & -12

Will screw directly onto, CP2623, CP4623, CP5623 and CP6093 cylinders by removing inlet adaptor.

Note: For fitting instructions refer to leaflet P14.073 on website.

www.apracing.com/car/cylinder/fluiddata.asp?code=cp4709dfit.

- **CP4709-13, -14 & -15** are for remote use but will fit directly to CP4400 master cylinders.

- **CP4709-16 & -17.**

are for remote use only.

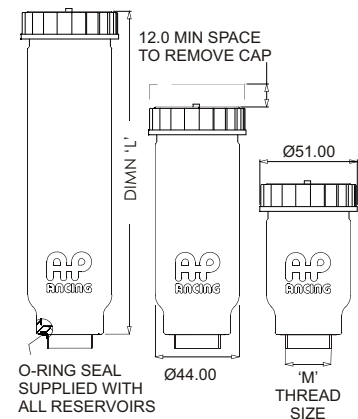

Part Number.	Type.	Volume CC'S	Dim'n 'L' (mm)	Thread Size
CP4709 -10	Tall	183.0	169.0	15/16" x 20 UNS
CP4709 -11	Med	123.0	119.0	
CP4709 -12	Short	75.0	79.0	
CP4709 -13	Short	75.0	96.0	7/16" x 20 UNF
CP4709 -14	Med	123.0	136.0	
CP4709 -15	Tall	183.0	186.0	
CP4709 -16	Short	75.0	96.0	M12 x 1.0
CP4709 -17	Med	123.0	136.0	

CP4773 TYPE

CP4773-1 (7/16UNF outlet) and CP4773-2 (M12 outlet). The new reservoirs capacity are midway between, CP4709 and CP2293-141/3 types. Both assemblies have an offset outlet and are fitted with bellows (CP4773-102). Volume = 195cm³.

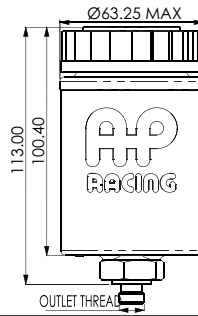

CP2293-141 / -143 & CP4623-7 / -8 TYPES

- A large capacity plastic reservoir with offset outlet which screws directly into the master cylinders detailed below.

- Can be supplied with or without rubber diaphragm, (CP2293-48).

- Supplied complete with cap 4325-148 & adaptor.

- **CP2293-141 & -143** suitable for: CP2623, CP4400, CP6093.

- **CP4623-7 & -8** suitable for: CP4623, CP5623.

- To rotate reservoir unlock nut included and reposition, then re-tighten.

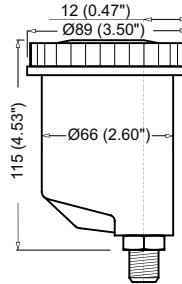

Part No.	Diaphragm.	Volume cm ³ (in. ³).	Fitting
CP2293-141	No	275 (13.4)	7/16" UNF
CP4623-7	Yes		M12x1.0
CP2293-143	Yes	275 (13.4)	7/16" UNF
CP4623-8	No		M12x1.0

CP2293-162 & -163

- Two extra large capacity plastic reservoir with either offset or central outlets which screws directly into all master cylinders with 7/16" UNF inlet thread.

- Volume = 340cm³ (20.7in³)

- Supplied with CP2293-166 rubber diaphragm (Bellows) to minimise entry of moisture, dirt and help prevent spillage.

- Supplied complete with cap 4325-148 & adaptor.

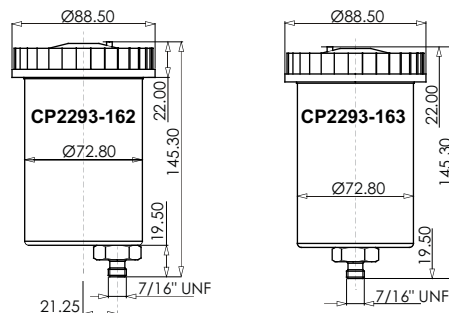

112009

- A remote plastic reservoir, accepts Ø5/16" hose.

- Complete with steel mounting bracket and cap 3847-241

- Volume = 185cm³ (11.3in³)

- No Diaphragm available.

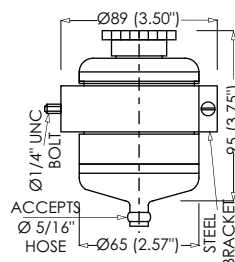

CP2293-69 & 4342-372

- A large capacity remote plastic reservoir with 1 outlet.

- **CP2293-69** supplied with diaphragm (bellows).

- **4342-372** supplied without diaphragm (bellows)

- Accepts Ø5/16" diameter hose.

- Volume = 280cm³ (17.1in³).

- Supplied complete with cap 4325-148.

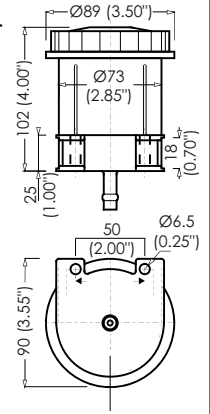

CP2293-85 & 4342-355

- A large capacity remote plastic reservoir with 2 outlets.

- **CP2293-85** supplied with diaphragm (bellows).

- **4342-355** supplied without diaphragm (bellows)

- Accepts Ø5/16" diameter hose.

- Volume = 280cm³ (17.1in³)

- Supplied complete with cap 4325-148.

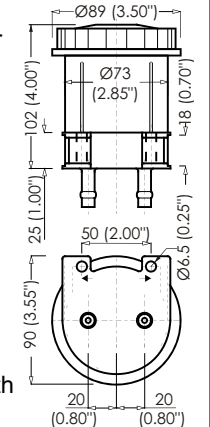

DIAPHRAGMS (BELLOWS)

Rubber Diaphragms (bellows) minimise the entry of moisture and dirt to help prevent spillage. The diaphragms listed below are suitable for use with the AP Racing reservoirs in this catalogue.

NOTE: The use of Diaphragms (bellows) may restrict effective volume or reservoirs.

CP2709-156 (SMALL)

- For use with reservoir cap 4325-151, on the following reservoir assemblies.

- All CP4709 Series



CP2293-48 (MEDIUM)

- For use with reservoir cap 4325-148, on the following reservoir assemblies.

- CP2293-141, -143 & -69
- CP4623-7/ -8/ -9 & -10



CP2293-166 (LARGE)

- For use with reservoir cap 4325-148, on the following reservoir assemblies.

- CP2293-162 & -163



BLEEDSCREWS

<p>CP4469-101 M7 x 1.0</p> 	<p>CP3720-107 M10 x 1.0 With lockwire hole.</p> 	<p>CP3720-173 M10 x 1.0</p> 	<p>CP3720-182 3/8" x 24UNF</p> 	<p>CP3880-1 M10 x 1.0 Sealed bleed screw -kit. Kit contains 2 x CP4970-125 & 2 x CP4970-124.</p> 	<p>CP3880-2 3/8" x 24UNF Sealed bleed screw -kit. Kit contains 2 x CP5820-115 & 2 x CP6297-111.</p> 
--	---	---	--	---	---

BANJO'S

<p>Single's CP2703 - 3/8" x 24UNF CP2677 - M10 x 1.0</p> 	<p>Double's CP2673 - 3/8" x 24UNF CP2674 - M10 x 1.25 CP2675 - M10 x 1.0</p> 	<p>Steel Braided CP2672 - For -3 steel braided hose</p> 
---	---	---

RESERVOIR INLETS

Inlets for CP4709 type fluid reservoirs.

<p>CP4709-105 7/16" UNF Use with 'O' Ring CP4709-104</p> 
<p>CP4709-106 M12 x 1.0 Use with 'O' Ring CP4709-104.</p> 
<p>CP4709-107 Push-on Use with 'O' Ring CP4709-104.</p> 

ADAPTOR KITS

Push-on Adaptors
CP2623-30 - 7/16" UNF
CP4623-2 - M12 x 1.0
accepts 7.9mm (5/16") inside Ø hose



Push-on Banjo Adaptor
CP2623-41 - 7/16" UNF
CP4623-6 - M12 x 1.0
accepts 7.9mm (5/16") inside Ø hose



RESERVOIR ADAPTORS

CP2623-167 - 'A' = 7/16" UNF
For CP2709-10/ -15/ -16 & CP2293-141/ -143 Reservoirs
CP4623-107 - 'A' = M12 x 1.0
For CP4623-4/ -5/ -7/ -8 Reservoirs

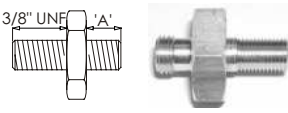

Use with 'O' Ring CP4623-435

Push-on Adaptor
CP2623-250



Use with 'O' Ring CP4623-435

ADAPTORS

CP2270-16
3/8" x 24UNF flat seat & convex seat.



CP2554-108
M10 x 1.0 flat seat & 3/8" x 24UNF convex seat.



CP2451
3/8" x 24UNF flat seat & 1/8" BSP concave seat.



INLET FITTINGS

Special inlet fittings for CP6465 Master Cylinder.
Note: These fittings are sold in kits complete with keeper plate, retaining screw & 'O' Ring.

<p>CP6465-10 75° Angle Fitting Kit</p> 
<p>CP6465-11 Straight Fitting Kit</p> 

REMOTE HOSE

CP6614-101 - 'L' = 609.0mm (24")
CP6614-102 - 'L' = 1828.0mm (72")
CP6614-103 - 'L' = 305.0mm (12")

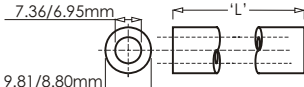

CLIP

CP2020-1
to suit outside Ø9.5mm to 13mm



COPPER GASKETS

	<p>KL44517 'A' 14.2 (0.56") 'B' 10.2 (0.40") 'C' 2.0 (0.08")</p>	<p>KL44518 'A' 17.5 (0.69") 'B' 11.1 (0.44") 'C' 1.6 (0.06")</p>	<p>KL44519 'A' 20.3 (0.80") 'B' 12.9 (0.51") 'C' 1.6 (0.06")</p>	<p>KL44520 'A' 17.0 (0.67") 'B' 12.9 (0.51") 'C' 1.22 (.048")</p>	<p>KL44539 'A' 29.5 (1.16") 'B' 24.1 (0.95") 'C' 1.22 (.048")</p>
---	--	--	--	---	---

ISOLATING VALVE

CP3388
Is a lever operated ball valve used in line to isolate a designated part of system.
Both inlet and outlet are 1/8" BSP threads.

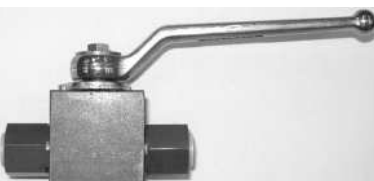
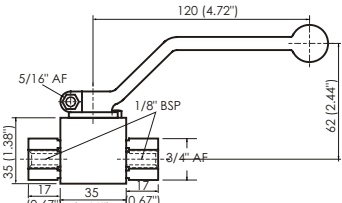
CP6465-12
90° Angle Fitting Kit





AP Racing brake fluids have been developed specifically for use under arduous conditions encountered at the highest levels of motorsport. AP Racing brake fluids are compatible with all conventional hydraulic brake systems designed to conform to S.A.E J1703 & J1704 requirements. The brake fluids below offer the user the ultimate in performance, reliability and budget whether you compete in F1, Rally, Sportscar or simply for the road. Supplied in heat sealed 500ml bottles.

PRF660 BRAKE FLUID

- **Designation.**
PRF660
- **'Typical' Boiling Points**
- New Dry
320°C
- 'Wet' E.R.
199°C
- **Part Number.**
CP4660-20
(Case of 20x500ml bottles)



AP Racing's new PRF660 has a dry boiling point of 320°C (608°F), 20°C higher than other leading brands.

PRF660 has advanced moisture resistance properties, low levels of viscosity (for ease of bleeding), low levels of compressibility and meets DOT4 specifications.

PRF660 is suitable for all top levels of motorsport where abnormal temperatures are experienced. It should be noted that before using PRF660 fluid, any existing brake fluid should be drained completely from the brake system. The system should be thoroughly purged with new PRF660 and can be filled completely with new PRF660.

551 BRAKE FLUID

- **Designation.**
551
- **'Typical' Boiling Points.**
- New Dry
275°C
- 'Wet' E.R.
150°C
- **Part Number.**
CP7551-20
(Case of 20x500ml bottles)



551 fluid is suitable for all forms of motorsport and conforms to FMVSS 116 DOT3 specification and is magnesium compatible but has a higher boiling point than normal brake fluids intended for road use.

600 BRAKE FLUID

- **Designation.**
600
- **'Typical' Boiling Points.**
- New Dry
300°C
- 'Wet' E.R.
210°C
- **Part Number.**
CP3600-20
(Case of 20x500ml bottles)



AP Racing's 600 fluid has a dry boiling point exceeding 300°C and has been developed for racing applications where high temperatures are being experienced, e.g. when using carbon discs and the ultimate in brake fluid performance is required. It should be noted that before using 600 fluid, any existing brake fluid should be drained completely from the brake system. The system should be thoroughly purged with new 600 and can be filled completely with new 600 fluid.

FORMULA DOT 5.1 FLUID

- **Designation.**
Formula DOT 5.1
- **'Typical' Boiling Points.**
- New Dry
260°C
- 'Wet' E.R.
184°C
- **Part Number.**
CP4510-20
(Case of 20x500ml bottles)



Formula DOT 5.1 is AP Racing's new high performance non silicone based brake and clutch fluid. Formula DOT 5.1 is recommended for use in the hydraulic brake and clutch systems of all cars, for which a non petroleum based fluid is specified. Suitable for high performance applications including vehicles fitted with ABS and ESP, is suitable for road and track day use.

ANSWERS TO FREQUENT QUESTIONS

- All AP Racing Brake Fluids are Polyalkalene Glycol Ether based, not a silicone based fluid. AP Racing do not sell and do not recommend using a silicone based brake fluid with any of its products.
- 600 brake fluid is intended for competition use only.
- 551 can be used for either competition or road use.
- Colour variations may occur in brake fluid due to its manufacturing process. This has no effect on the quality and performance of the product.

WARNING

DO NOT USE a mixture of PRF660, 600 and 551 brake fluids or PRF660 or 600 and any other Polyalkalene Glycol Ether based brake fluid as damage to the brake system may occur due to the formation of crystals in the presence of moisture.

DO NOT USE PRF660 or 600 fluid in contact with any type of magnesium components (e.g. Gearbox / Clutch components) as a chemical reaction is caused resulting in gases being generated. This will prevent the clutch hydraulics from working efficiently and may damage the magnesium components.

To obtain the best performance from racing brake systems, bleed the system thoroughly, immediately prior to each event using AP Racing brake fluid from a new sealed bottle. This is particularly important in wet or humid conditions or when the brakes are excessively hot. Always use fresh fluid and replace bottle cap when not in use. Never re-use brake fluid. The use of a high temperature fluid should not be used as a substitute for proper brake cooling. Brake temperatures can be determined using AP Racing temperature stickers (CP2650-11) and thermal paints (kit Number, CP2649-5).

If you require advice please contact AP Racing Technical section.
- AP Racing brake fluid contains Polyalkalene Glycol Ethers. Keep out of reach of children.

- Never transfer to unmarked jars or bottles.
- Harmful if swallowed.
- Avoid excessive skin contact. Flush affected eyes with water and seek medical aid.
- Brake fluids will damage vehicle paint work if spilled.

GENERAL DESCRIPTION

These valves have been specially designed for use in competition vehicles where it is desired to reduce the hydraulic line pressure and therefore braking effort of the rear brakes to compensate for varying road / track conditions or vehicle handling characteristics.

- **CP3550-13** lever type valve provides the driver, or the co-driver with seven distinct settings from which to select the most suitable braking ratio.

NEW - CP4550-1 twin bore lever type, is a 2 in and 2 out valve. This valve enables the user to utilise original fluid pipe runs on Grp 'N' or similar applications where a tandem master cylinder (diagonal split system) is specified. This provides the driver, with seven distinct settings from which to select the most suitable braking ratio.

- **CP3550-14** screw type offers infinite adjustment within the limits of normal brake operation. With the cap screwed fully in no reduction in output pressure occurs, with the cap screwed fully out output pressure is reduced to approximately 1/3rd of input pressure.

INSTALLATION

To obtain the best performance using these valves, the brake balance should be biased towards the rear so that with the valve piped into the rear line and set in position 7 (or the cap screwed right in) where virtually no reduction occurs, the balance is as much to the rear as will ever be needed. Placing the control lever in positions either 6 to 1 (or screwing the cap outwards) will progressively reduce the rear line pressure giving more bias to the front.

WARNING

Due to internal adjustments set by AP Racing, do not strip these assemblies.
 - DO NOT attempt any modification of these valves.
 - Strictly for competition use only.

NOTE:-

These proportioning valves are suitable for use with any brake fluid that conforms to DOT 3, DOT 4 or DOT 5.1 standards, but best all round performance will be achieved with either AP Racing PRF660 or 600 brake fluids.

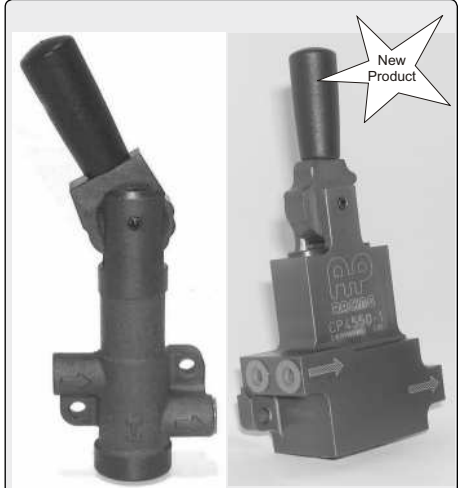

CP3550-13
Lever type.

CP4550-1
Twin bore lever type.



CP3550-14
Screw type.

**CP3550-13
Basic installations & Performance Details.**

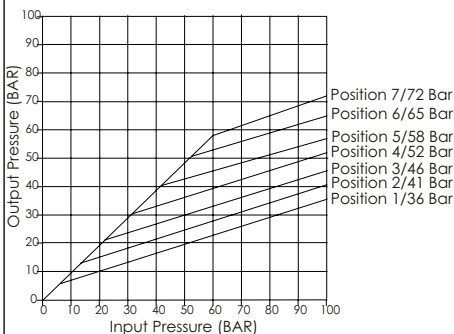
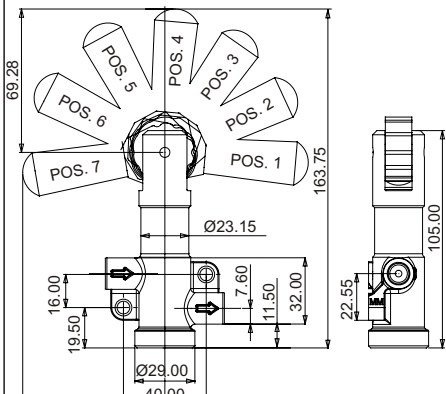

**CP4550-1
Basic installations & Performance Details.**

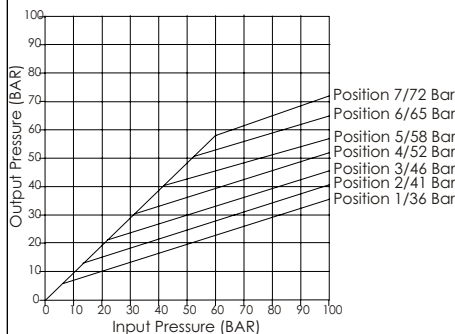
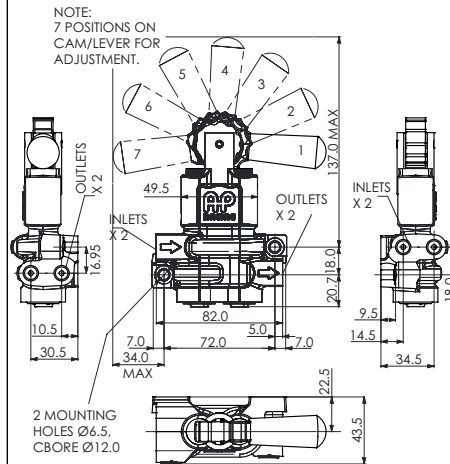

**CP3550-14
Basic installations & Performance Details.**

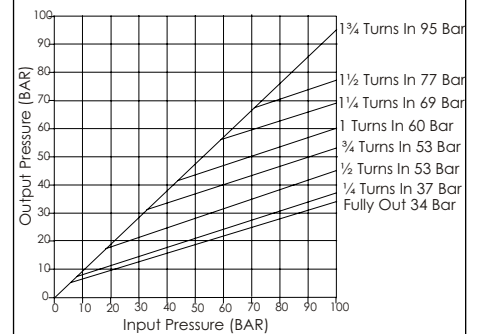
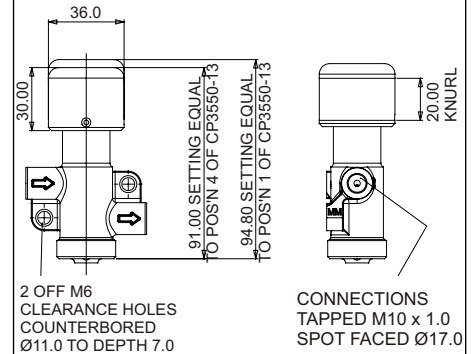



INTRODUCTION.

AP Racing's range of pedal boxes are proving to be masterpieces of functional design. Our pedal boxes represent a major step forward in chassis control, giving driver better feel, greater dexterity, quicker laps.

All pedal boxes are lightweight, flexible and ergonomically efficient, these multi-ratio pedal boxes are designed to harmonise with the complete range of master cylinders available from AP Racing.

**CP5500
FLOOR MOUNTED
PUSH TYPE.**



Conventional racing pedal box design available in 3, 2 and 1 pedal configuration, designed for comfort and control. Ergonomic forged pedals together with low friction treatments and a high quality spherical bearing set new standards in pedal box efficiency.

PART NUMBERS.

- CP5500- 2
Brake, Clutch & Throttle Assy.
- CP5500- 3
Brake & Clutch Assy.
- CP5500- 7
Brake Pedal Assy.

FEATURES.

- Aluminium base, machined from high quality die casting.
- Includes forged aluminium alloy Pedals and Balance Bar.
- Adjustable throttle pedal position.
- Brake and Clutch pedal Ratio 4.85:1.
- Suitable Master Cylinder Ranges.
 - CP2623 See page 68.
 - CP4623 See page 68.
- Recommended Push Rod Length
 - brake 88.0mm.
 - clutch 65.0mm.
- Mounting Holes M10.
- Adjuster cable CP2905-18 included with assembly.
- 10mm balance bar fitted with rubber boots to prevent dirt ingress.

CP5500-2 / THREE PEDAL

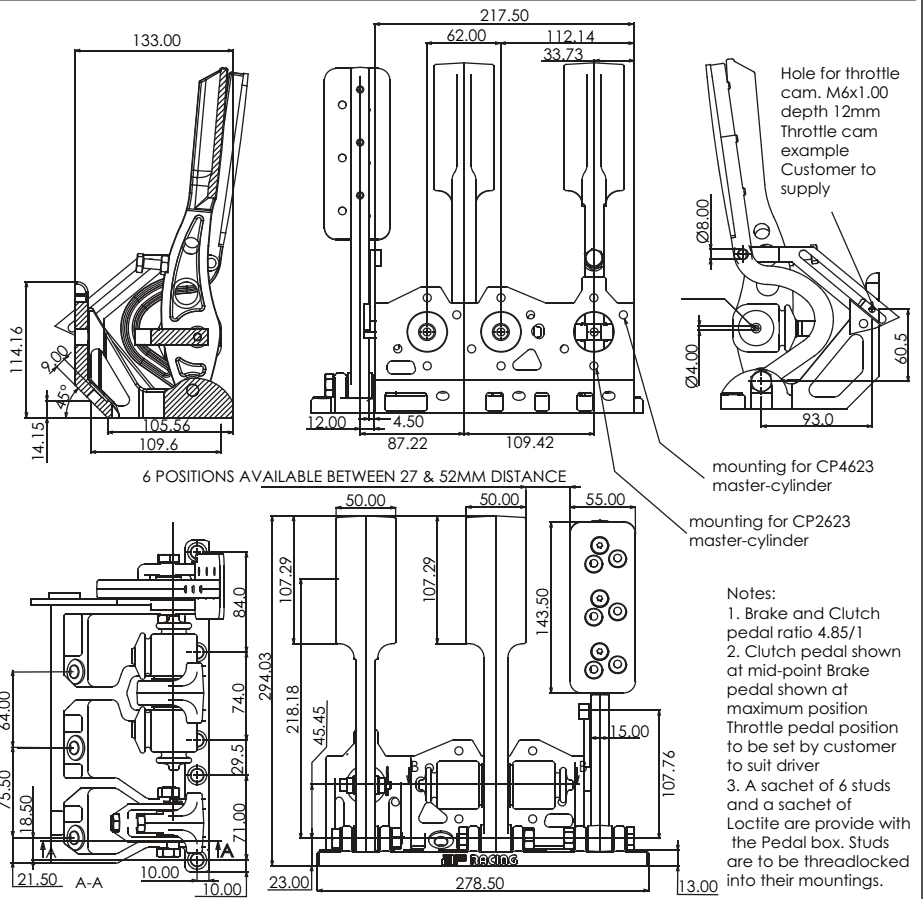

CP5500-3 / TWO PEDAL

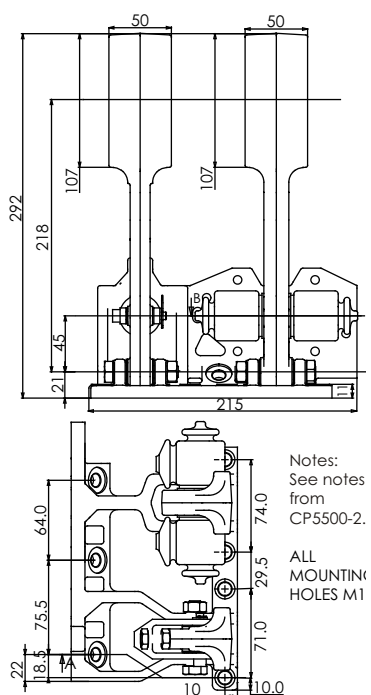

CP5500-7 / SINGLE PEDAL

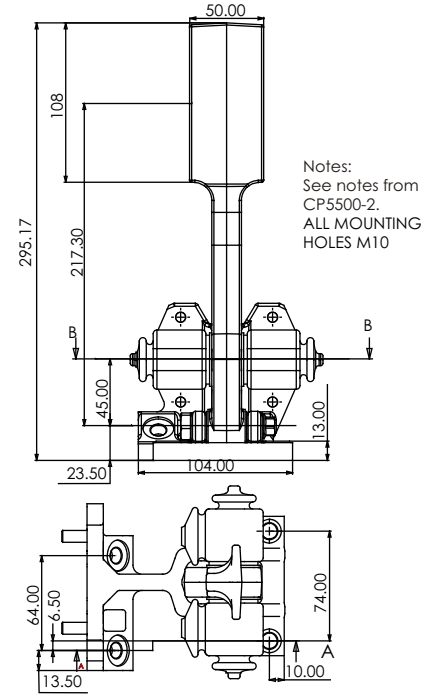

CP5509 FLOOR MOUNTED PUSH TYPE.

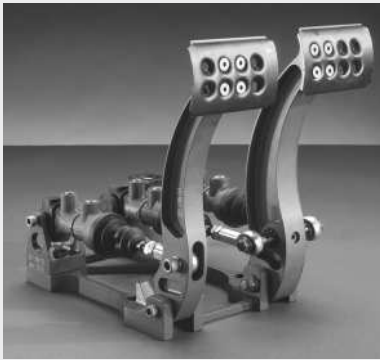

This is a general purpose floor mounted pedal box which utilises the latest high efficiency CP5854 push type Master Cylinders. Minimum hysteresis and balance variation are assured by the use of needle roller bearings in the centre trunnion and ball bearing pedal pivots.

PART NUMBERS.

- CP5509-1
Brake and Clutch Assembly.

FEATURES.

- Lightweight Billet base, machined from Aluminium.
- Includes billet aluminium alloy Pedals and Balance Bar.
- Adjustable foot pads for optimum driver comfort.
- Adjustable clutch stop.
- Brake and Clutch pedal Ratio 4.8:1.
- Brake and clutch pedal are pivoted on ball bearings for increased efficiency and smoothness.
- Designed for use with master cylinder.
 - CP5854 see page 70.
- Weight .
 - without cylinders 1.66kg
 - with cylinders 2.26kg
- Adjuster cable CP2905-18 included with assembly.

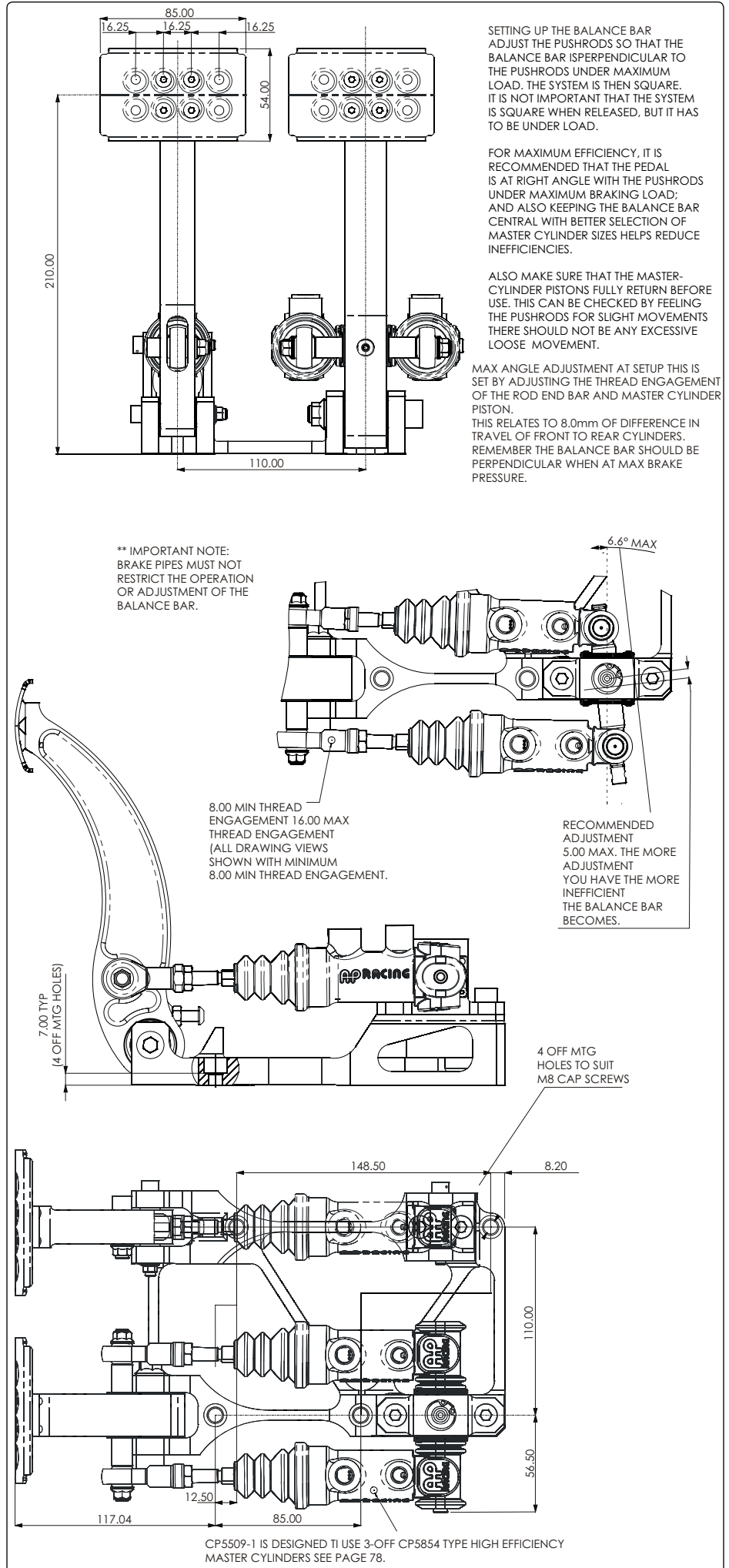

**CP5516
FLOOR MOUNTED
REVERSED PULL TYPE.**



This unique pull type design allows the pushrod to remain in line eliminating all side loads making it the most efficient pedal box on the market.

The cylinders are mounted under the drivers feet for optimum space utilisation and access. Minimum hysteresis and balance variation are assured by the use of needle roller bearings in the centre trunnion.

PART NUMBERS.

- CP5516- 3
Brake, Clutch & Throttle Assy.

FEATURES.

- Lightweight aluminium base, machined from high quality casting.
- All pedals are machined from aluminium billet.
- Brake pedal is pivoted by ball bearings to increased smoothness.
- Designed for use with master cylinder.
- CP6465 see page 71.
- Adjustable foot pads for extra driver comfort.
- Adjustable throttle pedal position, linkage with a torsion spring for positive pedal return.
- Adjustable pedal stops.
- Brake and Clutch pedal Ratio 4.8:1
- All threads are metric.
- Adjuster cable CP2905-18 included with assembly.

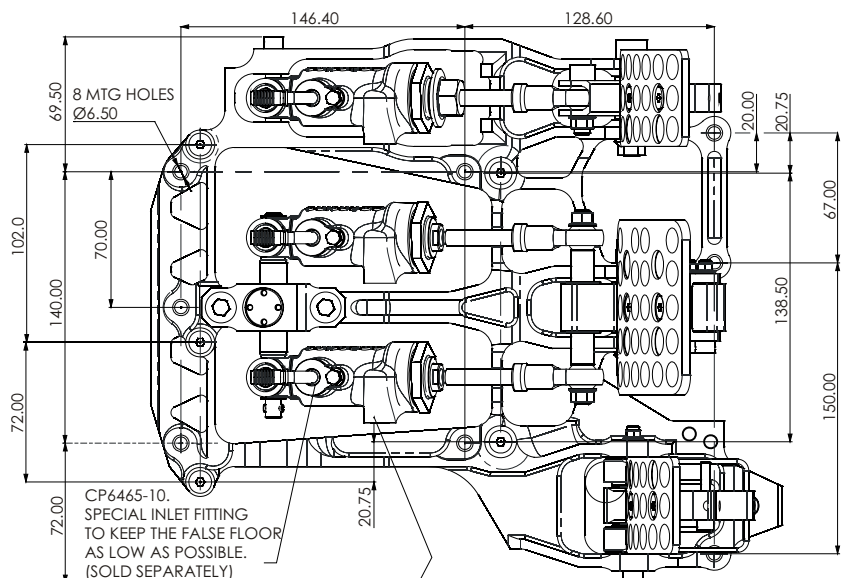
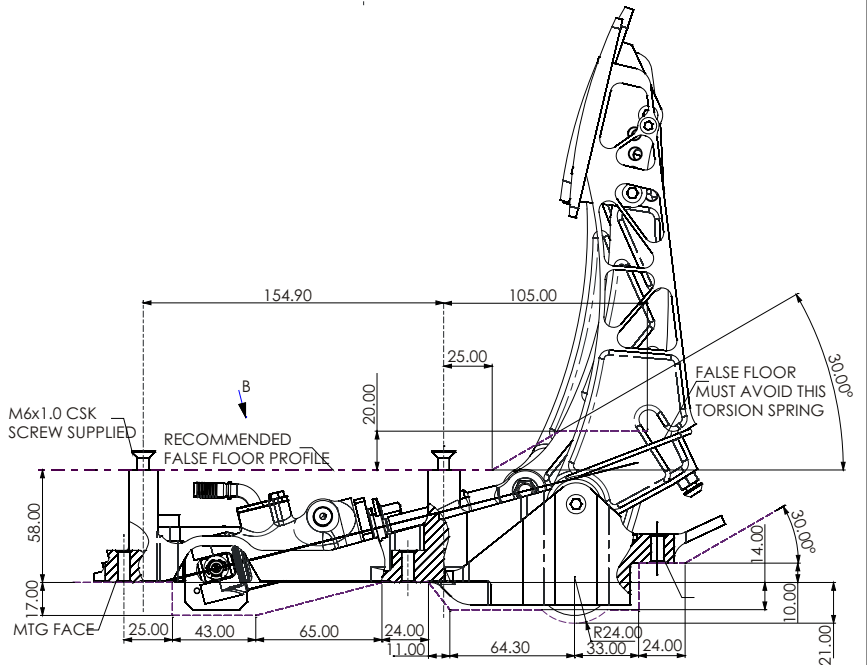
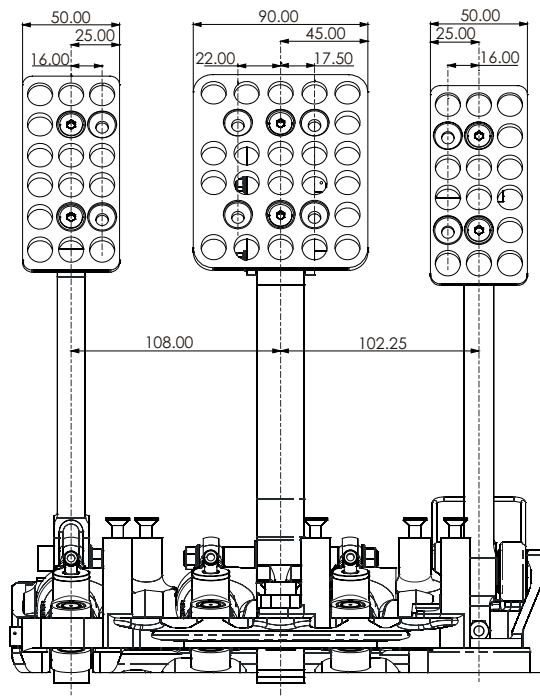

PEDAL BOX IS DESIGNED TO SUIT CP6465 HIGH EFFICIENCY MASTER CYLINDER. FEATURES:
 - BUILT IN LOW FRICTION CLEVIS. - SPECIAL INLET TO ALLOW A LOW FITTING. - M10x1.0 OUTLET PORT, SET AT 90°.
 - 25.4MM OF STROKE. - AVAILABLE IN VARIOUS SIZES. - SOLD SEPARATELY.

CP5507 UNDERSLUNG BULKHEAD MOUNT TYPE.



The bulkhead mounted type with master cylinders being located in the engine or front compartments. It's lightweight aluminium base, and ergonomic steel and alloy pedals offer the user the ultimate control in this critical area.

PART NUMBERS.

- CP5507- 19

Brake, Clutch & Throttle Assembly.

- CP5507- 18

Brake & Clutch Assembly.

- CP5507- 10

Throttle Pedal Assembly.

FEATURES.

- Lightweight aluminium base, machined from high quality casting.
- Fabricated Steel brake pedal.
- Machined aluminium alloy clutch and throttle pedals.
- Adjustable foot pads.
- Adjustable throttle pedal position & linkage.
- Adjustable pedal stops.
- Heavy Duty 12.7mm balance bar fitted with rubber boots and High quality spherical bearing.
- Adjustable cable CP2905-18 included with assembly.
- Brake and Clutch pedal Ratio 6:1.
- Suitable Master Cylinder Ranges,
 - CP6093 see page 69.
 - CP2623 see page 68.
 - CP4623 see page 68..
- All threads are imperial.

CP5507-19 / THREE PEDAL

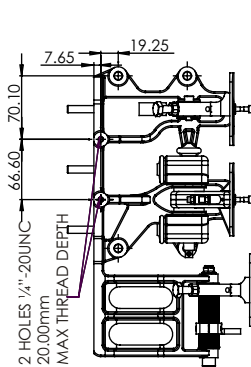
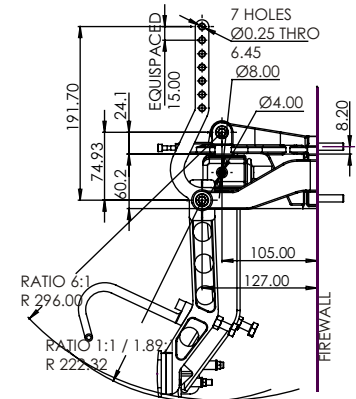
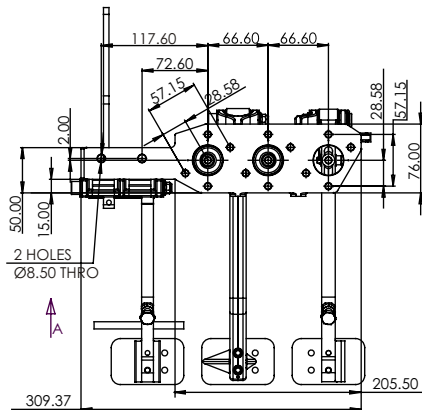
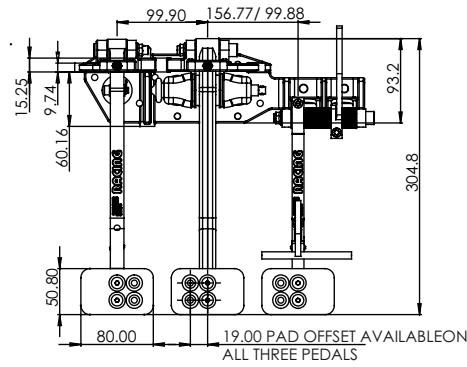

WHEN THE PEDALS ARE IN THEIR RELEASED POSITION THERE SHOULD BE 0.5MM (0.02") GAP BETWEEN THE END OF THE SCREW AND THE PEDAL. THE PEDAL SHOULD ONLY MAKE CONTACT WITH THE SCREW SHOULD A FAILURE IN THE MASTER CYLINDER OCCUR.

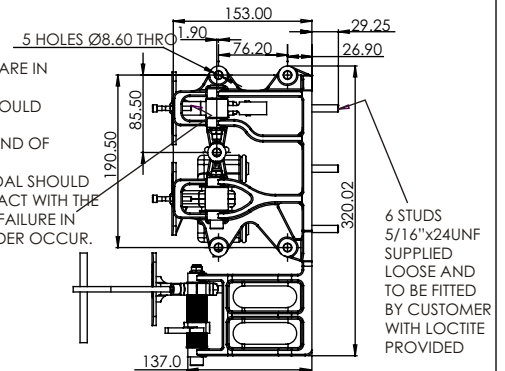

CP5507-18 / TWO PEDAL

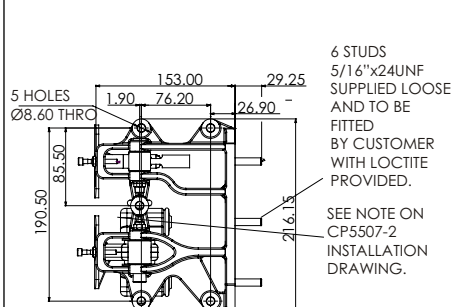
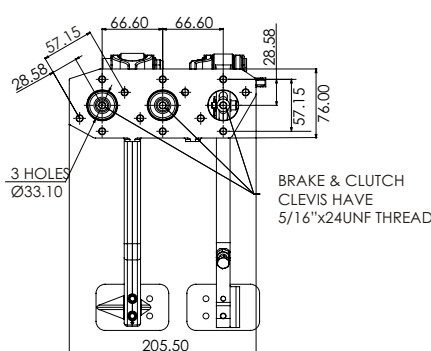

CP5507-10 / THROTTLE PEDAL

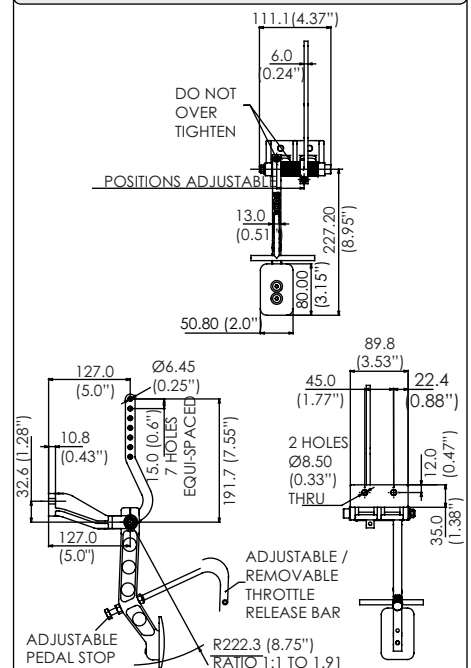

**CP5508
UNDERSLUNG MULTI
RATIO PUSH TYPE.**



This new multi ratio push type pedal box allows the pushrod to remain straight, eliminating all side loads therefore making it very efficient. The master cylinders connect directly to a high efficiency balance bar.

A lightweight aluminium base, and ergonomic steel and alloy pedals offer the user the ultimate control in this critical area.

PART NUMBERS.

CP5508- 1
Brake and Clutch Assembly

FEATURES.

- Lightweight aluminium base, machined from solid.
- Clutch pedal is machined from aluminium billet.
- Brake pedal is machined from steel.
- Brake pedal has multi ratios mounting bracket allowing three different ratio to be used.
- Brake pedal has a return spring fitted.
- Both pedals are pivoted on ball bearings to increase smoothness of feel for the driver.
- Adjustable stop on clutch pedal.
- Designed for use with CP5854 master cylinder see page 70.
- Weight.
 - without cylinders 2.12kg
 - with cylinders 2.72kg

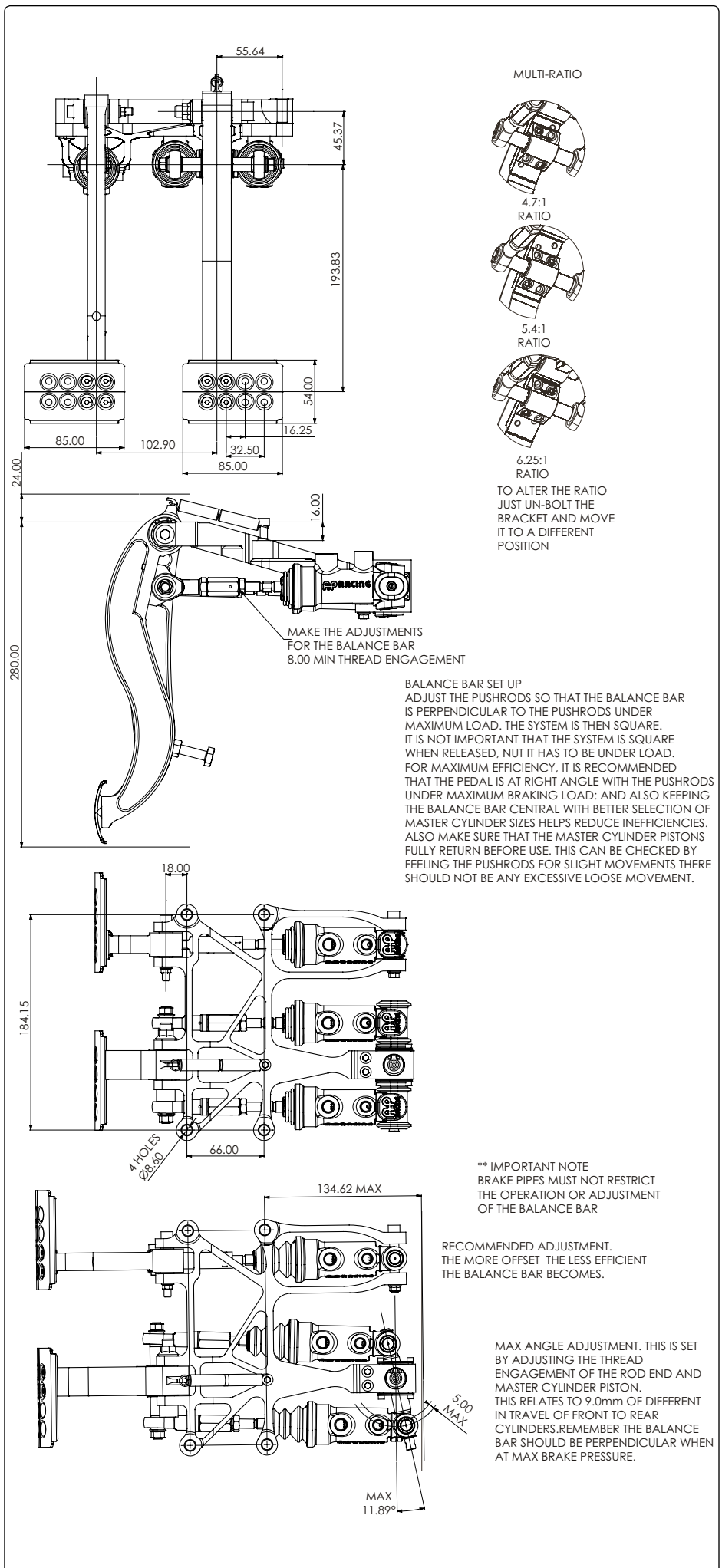

**CP5517
UNDERSLUNG BULKHEAD
PULL TYPE.**



This unique pull type bulkhead mount design with master cylinders being located in the engine or front compartments allows the pushrod to remain in line eliminating all side loads making it one of the most efficient pedal box on the market. It's lightweight aluminium base, and ergonomic steel and alloy pedals offer the user the ultimate control in this critical area.

PART NUMBERS.

- CP5517- 1
Brake and Clutch Assy.

FEATURES.

- Lightweight aluminium base, machined from high quality casting.
- Fabricated Steel brake pedal.
- Machined aluminium alloy clutch and throttle pedals.
- Designed for use with master cylinder.
- CP6465 see page 71.
- Bellows to seal the firewall. Made from fire retardant material.
- Adjustable foot pads for extra driver comfort.
- Adjustable throttle pedal position, linkage with a torsion spring for positive pedal return.
- Adjustable pedal stops.
- Brake and Clutch pedal ratio 4.8:1
- Adjuster cable CP2905-18 included with assembly.

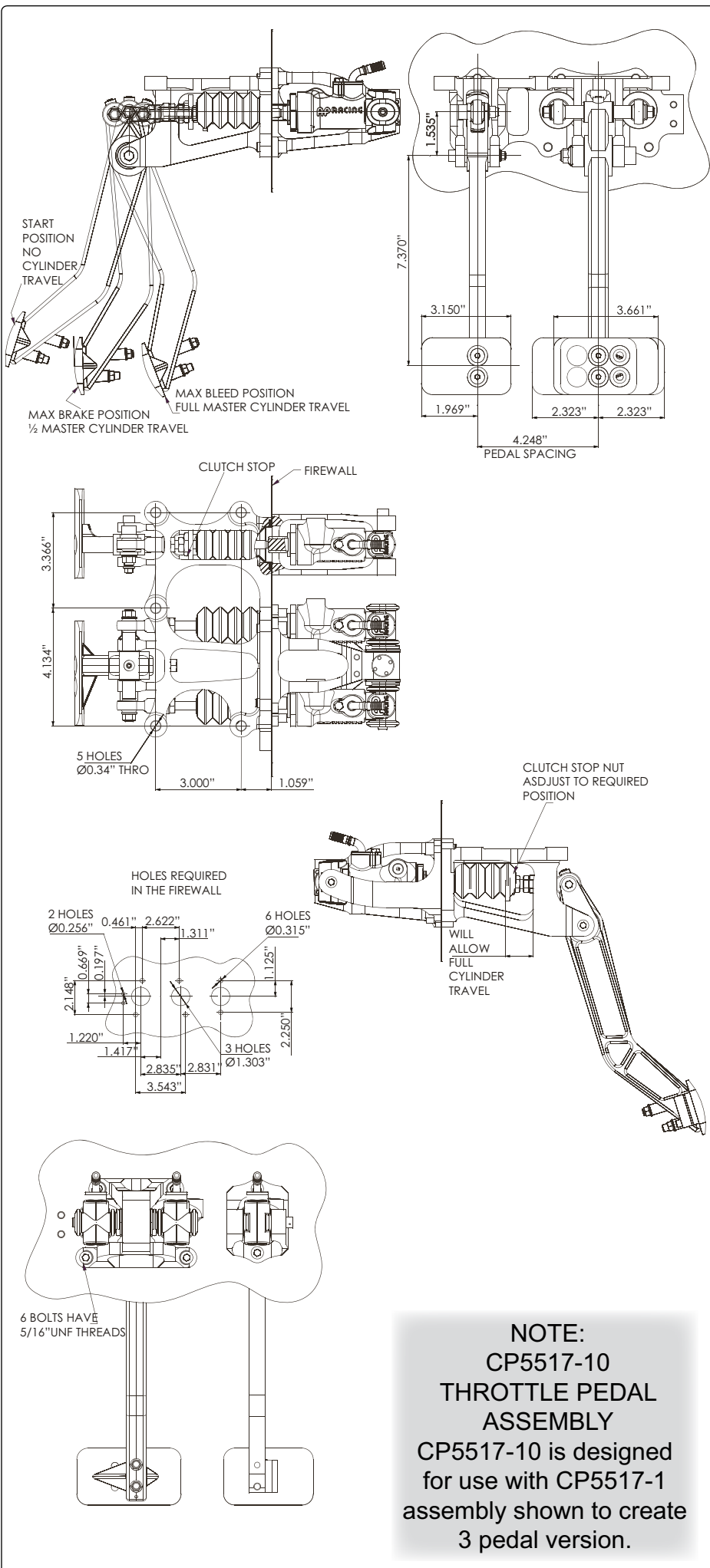



INTRODUCTION.

AP Racing's Balance Bar Assemblies have been designed to offer the user improved levels of efficiency and control. The range consists of four families:

CP5500-9 & CP5500-9UNF.

A lightweight and durable conventional Balance Bar manufactured from a high grade alloy steel treated with a low friction coating for extra smoothness of adjustment.

It incorporates a spherical bearing for improved efficiency, an outer tube to ease installation and rubber boots to prevent ingress of dirt & grit. Not suitable for heavy duty applications or high pedal ratios. A similar assembly is also available without the rubber boot CP5500-4.

NB. Select CP5500-9 for use with M8 Master Cylinder pushrods & CP5500-9UNF for use with 5/16"UNF Master Cylinder pushrods.

CP5507-2.

Similar in concept to CP5500-9 but with a heavy duty 12mm balance bar for applications where a high pedal ratio and / or heavy pedal loads are used. Features include low friction coatings, spherical bearing and rubber boots to prevent dirt ingress. NB. Suitable for use with 5/16"UNF Master Cylinder pushrods.

Note: CP5500-9 & CP5507-2

NB. If used with conventional master cylinders with articulated push rods e.g. CP2623, CP4623 etc. The push rod angularity must be limited to 4° from straight to avoid unacceptable side loads on the pistons.

CP5520-13 TRUNNION STYLE.

A new concept in balance bars where the central pivot is a trunnion rather than a spherical bearing. This has the advantage of preventing balance bar movement in the vertical plane thus removing the largest cause of unwanted balance variation. The centre trunnion and clevises employ needle roller bearings to reduce friction and hysteresis to a minimum, improving modulation.

CP5520-13 can be attached to the pedal or to the fixed end of the master cylinder and has been designed primarily for use with cylinders of the CP5855 type having a one piece piston and push rod. For use with 5/16"UNF threaded pushrods.

A similar balance bar **CP5520-2** without the end clevises is available for use with cylinders, such as CP6465 and CP5854 which have integral clevises and barrel nut.

CP5520-3 ANGLED TRUNNION

CP5520-4 STRAIGHT TRUNNION

HIGH EFFICIENCY BALANCE BARS.

These small and compact balance bars use needle roller bearings, to provide low hysteresis and high efficiency. These versions are designed to fit at the fixed end of master cylinders fitted with integral trunnions such as CP6465 (Pull Type) and CP5854.

CP5500-9 BALANCE BAR.

THE ASSEMBLY IS SUPPLIED WITH:
- 2 M3x0.5 GRUB SCREWS FOR CABLE FITTING (TAPPED HOLE IN BALANCE BAR) - 2 EXTERNAL CIRCLIPS Ø32- 1 BISSEL PIN Ø3 x30MM

FIGURE 2: RECOMMENDED HOUSING DIMENSIONS

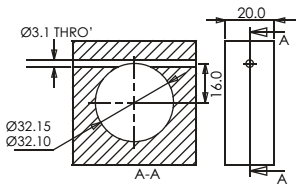
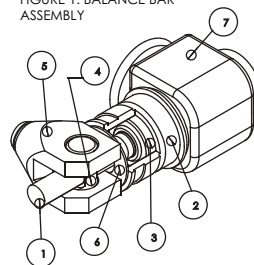
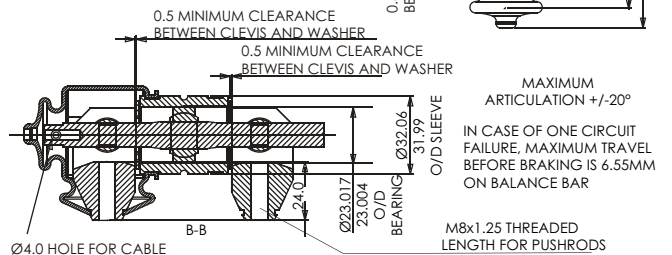
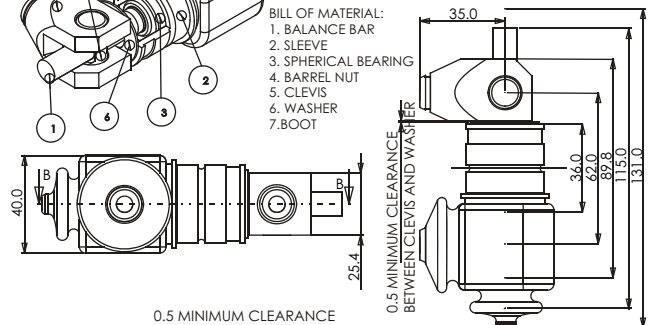

FIGURE 1: BALANCE BAR ASSEMBLY



BILL OF MATERIAL:
1. BALANCE BAR
2. SLEEVE
3. SPHERICAL BEARING
4. BARREL NUT
5. CLEVIS
6. WASHER
7. BOOT

FIGURE 3: MAIN DIMENSIONS



Ø4.0 HOLE FOR CABLE ADJUSTER.
AP RACING CP2905-18
AVAILABLE ON REQUEST

INSTALLATION.

A. Sleeve

1. Make a hole in the pedal of the recommended dimensions (Fig 2.) The centre has to be at the same height as the master cylinder centreline when pedal is square to the master cylinder.
2. If you wish to retain the sleeve with a Bissel Pin, drill a hole in the pedal as shown on Fig 2.
3. Position the sleeve in the pedal. It is recommended to bond the sleeve into the housing to minimise the play of the balance bar. Depending on the configuration you chosen, put the circlips or the Bissel Pin in place.



B. Balance Bar Installation

1. Grease the housing inside diameter (2) and spherical bearing (3).
2. Install balance bar (1) inside sleeve (3)
3. Install the clevis (5), barrel nut (4) and washers (6) into the rubber boots. Hang clevis to boot with groove on front of clevis.
4. Screw the barrel nuts (4) on the balance bar (1). Leave one turn minimum clearance between the clevis (5) and the washers (6).
5. Install remote cable and retaining screws.
6. Install M8 nuts provided on master cylinder pushrods.
7. Adjust the pushrods so that the balance bar is perpendicular to the pushrods under maximum load. The system is then square it is not important that the system is square when released, but it has to be under load. For maximum efficiency, it is recommended that the pedal is at right angle with the pushrods under maximum braking load. Also make sure that the master cylinder pistons fully return before use. This can be checked by feeling the pushrods for slight movements. There should not be any excessive loose movement. The washers (6) should be loose during the full pedal travel. If not back off one clevis and barrel nut another turn.

CP5507-2 BALANCE BAR.

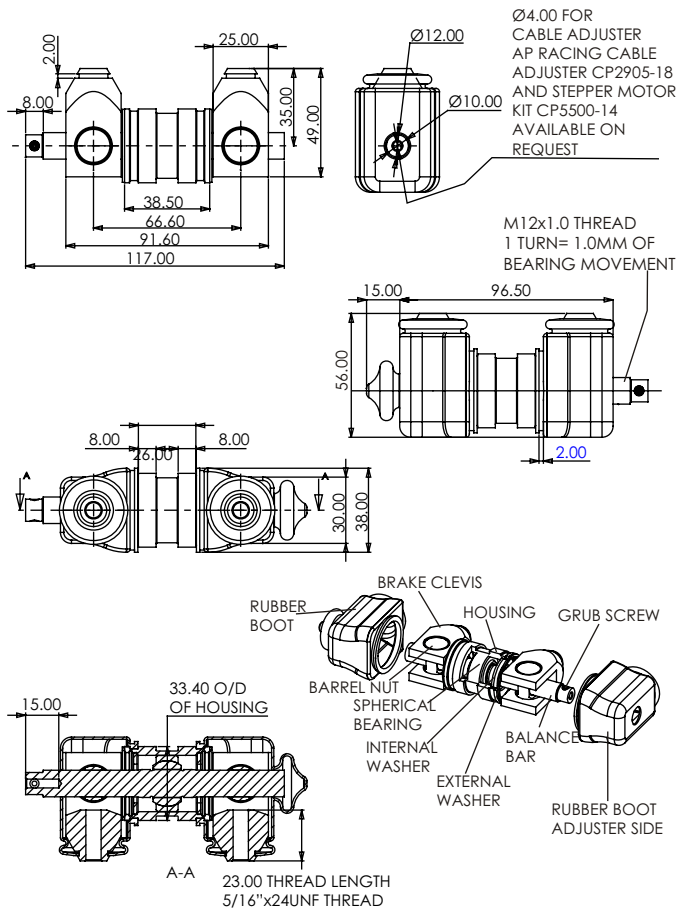

INSTALLATION.

1. Position housing into a hole of required diameter (33.50) in the brake pedal. This hole should be positioned such that under normal braking loads the centre is in line with the master cylinder bores.
 2. Weld or bond the housing in position.
 3. Grease the bore of the housing and the outer race of the spherical bearing.
 4. Insert the balance bar with the bearing attached, into the housing with the adjuster end at the desired side.
 5. Insert the 2 internal washers into the housing & retain with circlips.
 6. Place external washers over balance bar and then screw on both clevis's and barrel nuts until they start to bind. Then rotate one of them back one turn.
- Tip: Half turn adjustments can be made by taking one clevis and barrel nut back to the end of the balance bar, flipping the clevis over, and then threading the barrel nut back into place.
7. Stretch boots over the clevis's and locate them on the grooves on the housing and clevis's.
 8. Attach adjuster to the end of the balance bar using grub screws.
 9. Screw in push rods and adjust so that under normal braking the balance bar lies perpendicular to the push rods and the pedal is vertical. It is not important if the balance bar is not square when released, but it should be whilst braking for maximum efficiency.
- Tip: Adjustment of the push rods is made easier by running one of the two nuts supplied with each master cylinder to the end of the thread to allow the use of a spanner.



CP5520-13 TRUNNION BALANCE BAR.

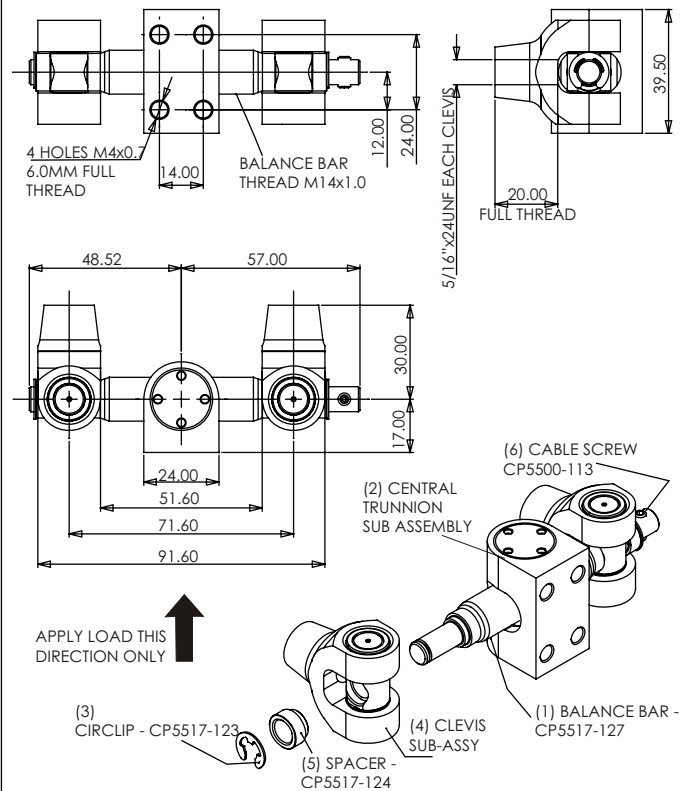

NB: CP5520-2 AVAILABLE WITHOUT CLEVIS ASSEMBLIES

INSTALLATION.

A. Fitting the Balance Bar to the Pedal

1. Make 4 holes in the pedal of the recommended dimensions. The centre has to be at the same height as the master cylinder centreline when pedal is square to the master cylinder.



2. In positioning the balance bar on the pedal, please take notice of the direction of load, as shown. It may effect the position you choose.

B. Fitting the Clevis to the Balance Bar

1. Install balance bar (1) inside the central trunnion sub-assy (2).
2. Push the clevis sub-assy (4) on to balance bar (1).
3. Push the washer (5) against the clevis sub-assy (4)
4. Push circlip (3) in to place on balance bar (1) to hold clevis sub-assy (4) in place.

C. Setting up the Balance Bar

1. Install remote cable and retaining screws (6).
2. Install nuts provided on master cylinder pushrods.
3. Adjust the pushrods so that the balance bar is perpendicular to the pushrods under maximum load. The system is then square. It is not important that the system is square when released, but it has to be under load.

For maximum efficiency, it is recommended that the pedal is at right angle with the pushrods under maximum braking load; and also keeping the balance bar central with better selection of master cylinder sizes helps to reduce inefficiencies. Also make sure that the master cylinder pistons fully return before use. This can be checked by feeling the pushrods for slight movements there should not be any excessive loose movement.

CP5520-3 & CP5520-4 TRUNNION BALANCE BAR.

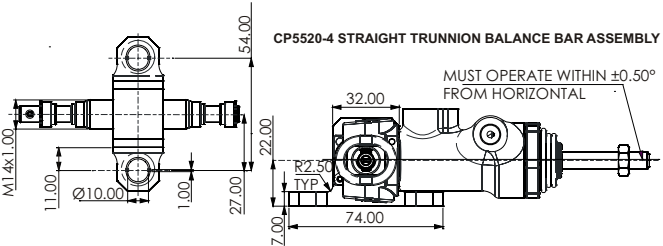
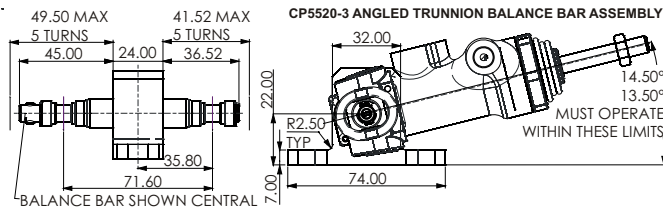

MAXIMUM RECOMMENDED ADJUSTMENT
The maximum recommended adjustment allowed is 5.00mm or 5 turns in either direction.

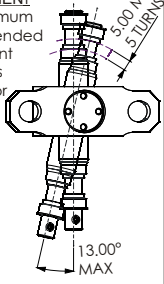

M4x0.50 HOLE FOR CABLE ADJUSTER, 2 OFF M4x0.50 GRUB SCREWS TO RETAIN CABLE INCLUDE. AP RACING CABLE ADJUSTER - CP2905-18

- SPARES:
- 1 - BALANCE BAR - CP5517-127
 - 2 - SPACER - CP5517-124
 - 3 - CIRCLIP - CP5517-123
 - 4 - CABLE SCREWS - CP5500-113
 - 5 - TRUNNION BAR ASSY
 - 6 - M3 BUTTON HEAD SCREW - CP3714-119
 - 7 - BOOT CLAMPING PLATE - CP5517-145
 - 8 - RUBBER BOOT - CP5517-144

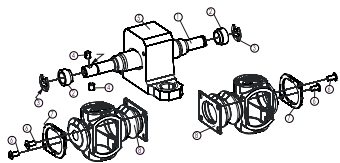

These small and compact balance bars use needle roller bearings, to provide low hysteresis and high efficiency. These versions are designed to fit at the fixed end of master cylinders fitted with integral trunnions such as CP6465 (Pull Type) and CP5854.

INSTALLATION.

A. Fitting the Balance Bar.

Please make sure the cylinder angle is correct to the balance bar, otherwise it will fail to operate properly. This means the balance has to be fitted at the fixed end.



B. Fitting the Master Cylinder Clevis to the Balance Bar.

1. Instal balance bar (1) inside the central trunnion sub-assembly (5).
2. Place master cylinder clevis on to balance bar (1).
3. Push the washer (2) on the balance bar (1).
4. Push circlip (3) into place on balance bar (1) to hold master cylinder clevis in place. Cylinder should be able to rotate on the balance bar.

C. Setting up the Balance Bar.

1. Install remote cable and retaining screws (4).
2. Adjust the cylinder pullrods so that they are perpendicular to the balance bar under maximum load. It is more efficient when perpendicular. It is not important to be perpendicular when released.

For maximum efficiency, it is recommended that the pedal is at right angle with the pushrods under maximum braking load; and also keeping the balance bar central with better selection of master cylinder sizes helps to reduce inefficiencies. Also make sure that the master cylinder pistons fully return before use.

Special Note: The more adjustment you have the more inefficient the balance bar becomes

CP2905-8 (WITH END CONNECTOR) CP2905-18 (WITHOUT END CONNECTOR) CABLE ADJUSTERS.



Is a high quality Balance Bar Cable Adjuster ideal for any competition vehicle Anodised aluminium alloy body with ¼ turn click stops for positive vibration proof positioning. The Ø3.8mm inner steel cable has a polyethylene 'FR' self extinguishing outer tube and is generally stiffer than most adjuster cables on the market to resist 'wind up'. The adjuster body can easily be fitted through a Ø19mm hole in the dashboard. Supplied in 1200mm lengths with an adjustable end fitting allowing the cable to be cut to the required length, the kit includes cable clips and two directional stickers.

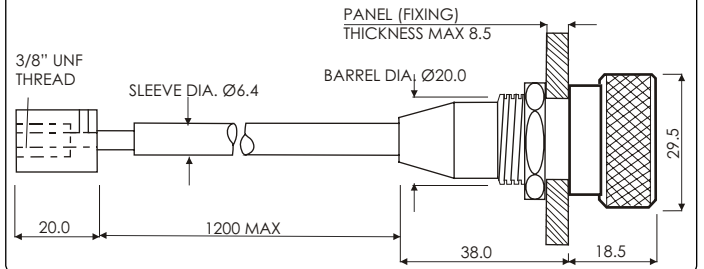

CP2905-15 CABLE ADJUSTER WITH DIGITAL READ-OUT.



Incorporates the CP2905-8 Balance Bar Cable Adjuster. The balance bar digital read-out provides the user with an accurate indication of exact position of the balance bar to the right or the left of centre. The illuminated display is mounted in a plastic housing with two fixing points

for mounting to the dashboard and is supplied with approximately 18" of cable to the transducer. The adjuster body can be fitted through a Ø19mm hole in the dashboard or bulkhead also using the mounting plate for increased security.

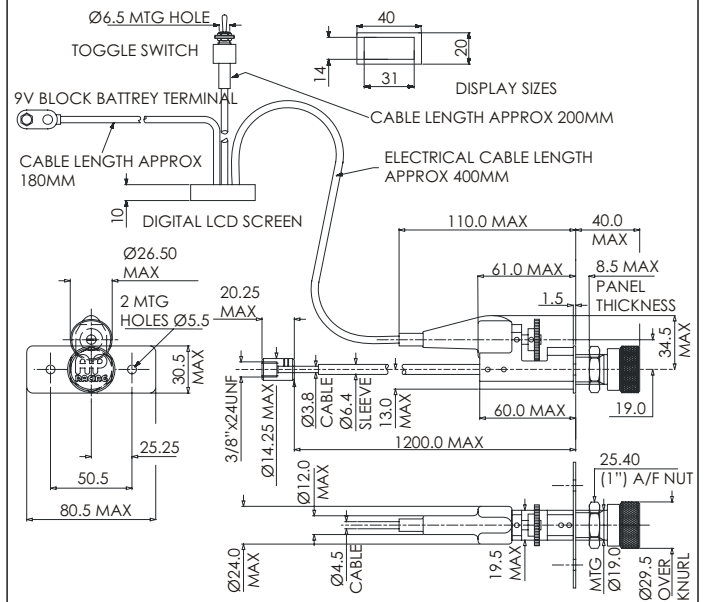

INSTALLATION OF ADJUSTER CABLES

Ensure that the balance bar is correctly installed and turns freely (see above). The cable should not be installed with any bends of less than 50mm (2") radius otherwise wind-up may occur. For maximum stiffness the outer cable should be securely fastened in place along its complete length using the clips provided. Cut the cable to the required length preferably using an elastic grinding wheel, secure end fitting to balance bar, insert cable and lock in place with grub screw.



AP Racing Air Jacks are designed to be both lightweight and reliable. They come in a number of configurations to suit different lift heights and vehicle weights. A range of accessories including exhaust valves and safety props, lances & connectors are also available. The CP3985 Fast Jacks are designed to provide the ultimate in speed and low weight and have a built in exhaust valve.

Do not exceed the recommended operating pressures.

- 20 Bars for CP2985, CP2995.
- 30 Bars for CP3985 type.

WARNING:

Explosive release of the energy stored in compressed air can be dangerous. Please read the notes below. Jacks & air connections should be examined regularly for signs of damage.

SAFETY, INSTALLATION & USE.

Never work under a vehicle supported only by Air Jacks unless safety props are fitted. Do not use 'U' bolt type clamps as distortion of the body will cause the Air Jack to stick. Do not loosen or remove adaptor. Jacks must be vertical during operation, Mounting brackets or clamps to be fitted to threaded section of body only. Do not use petrol or paraffin for cleaning the Air Jacks as this will damage the rubber seals. Use an alcohol based cleaning fluid e.g. Methylated spirit. Use only silicone spray or silicone grease when internal lubrication is necessary. Ensure end cap reinforcing ring (CP2995 Air Jacks only) is tightened before use. The connections on CP2985, CP2995 are designed for dash 6 Aeroquip fittings. CP3985 Air Jack have an M14 female inlet.

RECONDITIONING.

AP Racing have introduced two new tool kit to enable the user to recondition their Air Jacks.

- CP4985-10 kit contains all tools necessary to recondition all CP2985.

- CP4985-20 kit contains all tools necessary to recondition all CP3985 Air Jacks. See Pages 87 & 88 for information.

CP3985 SERIES - FAST AIR JACK.

CP3985 is an Air Jack that has a compression spring rather than the conventional tension return spring system. This makes the Air Jack faster and more efficient in operation.

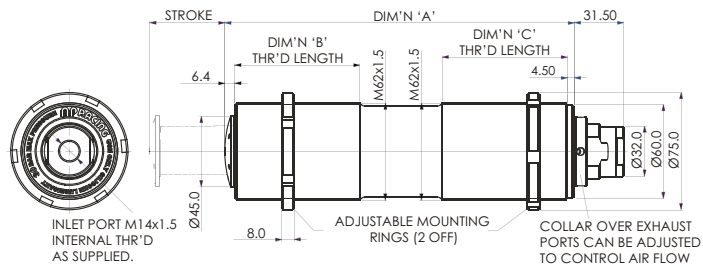

Part No.	Bore Size. (mm)	Stroke. (mm)	Lift Capacity.	Operating Pressure Max.	Weight.	Dimensions.			Safety Prop.
						'A'	'B'	'C'	
CP3985-130EV	54.0	130.0	675Kg.	30 Bar.	0.85Kg	202.0	80.0	80.0	CP3985-13
CP3985-150EV		150.0			0.88Kg	224.0			CP3985-15
CP3985-190EV		190.0			1.00Kg	275.0			CP3985-19
CP3985-230EV		230.0			1.12Kg	325.0			CP3985-23
CP3985-310EV		310.0			1.39Kg	425.0			CP3985-31

CP2995 SERIES - AIR JACK.

CP2995 is an Aluminium bodied Air Jack that is operated with tension return spring. CP2995 is not as fast as CP3985 but has a higher lift capacity of 1000kg.

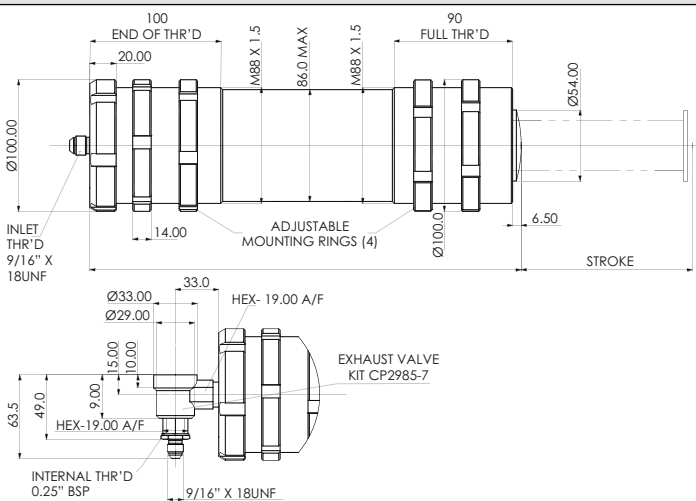

Part No.	Bore Size.	Stroke. (mm)	Lift Capacity.	Weight.	Dimensions.		Safety Prop.	Inlet Thread.
					'A'	'B'		
CP2995-1	79.0mm	230.0	1000Kg. At 20 Bar.	1.9Kg	328.1	CP2985-14	9/16x18 UNF	
CP2995-13		172.0		N/A	270.1	N/A		
CP2995-14EV		265.0		N/A	363.1	N/A		

Customers requiring an exhaust valve fitted please add 'EV' to the end of the part number. e.g. CP2995-1EV.

CP2985 SERIES - AIR JACK.

CP2985 is an Aluminium bodied Air Jack that is operated with tension return spring. CP2995 is not as fast as CP3985 but is slimmer in design, with a lift capacity of 475kg.

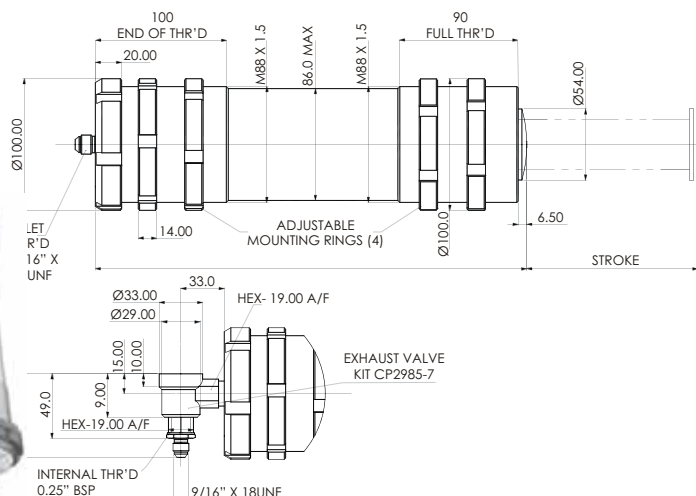

Part No.	Bore Size.	Stroke. (mm)	Lift Capacity.	Weight.	Dimensions.				Safety Prop.	
					'A'	'B'	'C'	'D'		
CP2985-1	54.0mm	230.0	467Kg. At 20 Bar.	1.3Kg	320.5	9.0	90.0	90.0	CP2985-14	
CP2985-10		168.0		1.1Kg	259.5	59.5	59.5	59.5	N/A	
CP2985-15		310.0		1.6Kg	400.5	150.0	90.0	90.0	90.0	CP2985-17
CP2985-25		153.0		1.0Kg	244.5	90.0	90.0	100.0	N/A	
CP2985-29		310.0		/	400.5	150.0	90.0	210.0	210.0	CP2985-17

Customers requiring an exhaust valve fitted please add 'EV' to the end of the part number. e.g. CP2985-1EV.

**CP3985 FAST AIR JACK
SERVICING INSTRUCTIONS.
CP4985-20 TOOL KIT FOR USE WITH
CP3985-1RK REPAIR KIT.**

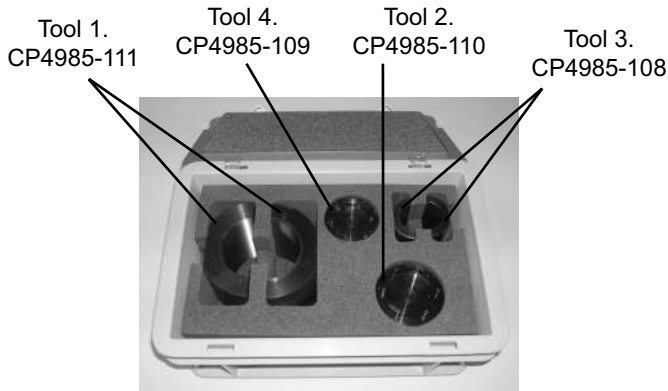

DIS-ASSEMBLY INSTRUCTIONS

1. Hold the Air Jack in a vice using the pair of threaded Body Clamps (Tool 1). Do not over tighten. (See Fig 1.)
2. Locate Pin Tool (Tool 2) into the Bearing Housing holes and unscrew anti-clockwise out of the Air Jack Body using either a Torque spanner and a 21mm socket or using a Tommy bar (not supplied) through the hole in the Pin Tool. (See Fig 1.)

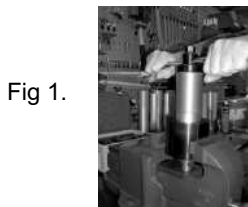

Fig 1.



Fig 2.

3. Once the Bearing housing is unscrewed completely from the Body, the Air Jack Piston Assembly can be withdrawn from the Body in one piece. (See Fig 2.)
4. If only cleaning and lubrication is to be carried out, then there is no need to dis-assemble the Air Jack further, but if the assembly is to be stripped down for replacement of all Bearings and Seals, then the following instructions apply.
5. Manually slide the Bearing Housing along the Air Jack Ram, compressing the Spring and slip the pair of Ram Clamps (Tool 3) around the Ram and between the Bearing Housing and the foot. Carefully release the Spring load to grip the Clamps. (See Fig 3.)

SAFETY NOTICE:- THE PENT UP SPRING FORCE IS POTENTIALLY HAZARDOUS. SO THIS OPERATION SHOULD BE CARRIED OUT WITH GREAT CARE. TO AVOID ACCIDENTS.

6. Hold the assembly in a vice using the Ram Clamps. Do not over tighten.



Fig 3.



Fig 4.



Fig 5.

7. Using Pin Tool (Tool 4) engaged in the holes in the foot, rotate anti-clockwise to unscrew the foot from the Ram. (See Fig 4.)
8. Carefully slacken the vice grip to release the assembly, (bearing in mind the safety note above in instruction 5). The Bearing Housing, small Bearing, Spring and Spacer (If fitted) can now be removed from the Piston Assembly.
9. The End Cap can be removed from the Body if necessary, using the Body Clamps (Tool 1) and a spanner applied to the 30mm flats on the Cap. (See Fig 5.)
10. Likewise the Inlet Adaptor can be unscrewed from the Cap using standard spanners to access the Valve Seal.
11. The Air Jack is now sufficiently dis-assembled to clean, lubricate and fit replacement parts.

AIR JACK SERVICING INSTRUCTIONS AND RE-ASSEMBLY

These notes assume that all metal components are in a re-usable condition. If any component is damaged beyond use, then the Air Jack should either be returned to AP Racing for full reconditioning, including replacement of the damaged components, or additional replacement parts will need to be ordered.

1. Remove all 3 O-rings and the Valve Cup Seal from the Cap, Inlet Adaptor and Piston and remove both plastic Bearings and discard. Make note of the orientation of the Valve Cup Seal, in order to re-assemble correctly later. Thoroughly clean all other metal components. Use an alcohol based cleaning fluid i.e. Methylated Spirit or warm soapy water. **DO NOT USE ANY PETROLEUM BASED CLEANERS AS THESE WILL DAMAGE THE RUBBER SEALS.**
2. Use the 3 O-rings, the Valve Seal and the two Bearings contained in Repair Kit CP3985-1RK to replace those parts discarded. In order to install the larger Bearing, it will be necessary to split it as shown in the instructions included in the repair kit. The smaller Bearing need not be split to install.
3. There is an O-Ring bonded into a groove in the foot to act as return stop, if this is missing or damaged, then it can be replaced with one from the repair kit. Use a small amount of Loctite 406 to fix the new O-Ring to the foot.
4. Apply Silicon Spray lubricant to the main Bore of the Body and pack the Main O-Ring groove of the piston with Silicon Grease as shown in (fig 6.). Take care not to allow lubricant onto any of the threads that are to be bonded with Loctite.

Position O-Ring in this groove, against the face shown. Pack the remainder of the seal groove with silicon grease.

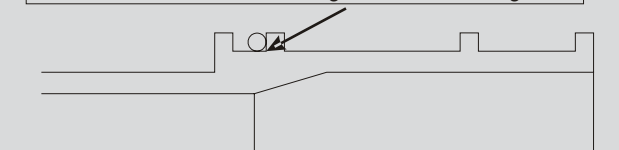
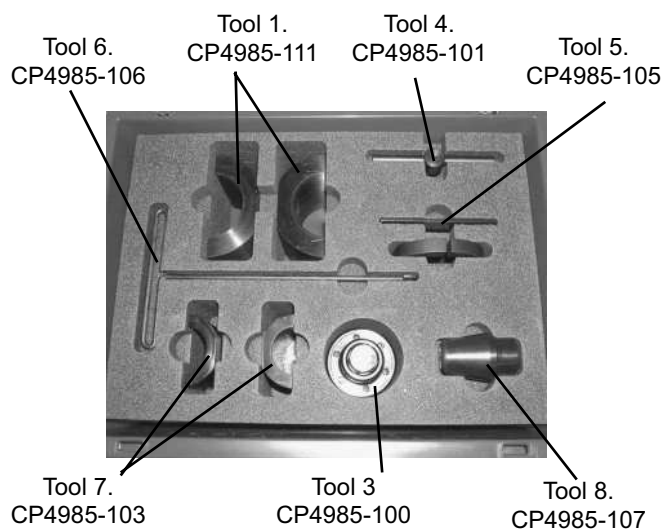

Fig 6.

5. Re-assembly is the exact reverse of the operations listed above.
6. The Foot is to be bonded to the Ram and the Cap is to be bonded into the Body using Loctite 270. Ensure threads are clean, apply Loctite Activator 7649 and then apply one complete circumferential ring of Loctite to the first turn only of the Male thread. Do not apply excess Loctite. With the Activator applied, the Loctite will set quickly, so apply the Loctite activator only just prior to threading any pair of parts together. Quickly screw parts together until fully seated, ensuring that any O-rings are correctly positioned and are not cut. Using the same tools used for dis-assembly, tighten all parts securely. Use a compressed air supply of 5 Bar maximum to check for leaks.

**CP2985 AIR JACK
SERVICING INSTRUCTIONS.
CP4985-10 TOOL KIT FOR USE WITH
CP2985-1RK REPAIR KIT.**



DIS-ASSEMBLY INSTRUCTIONS

1. Hold the Air Jack in a vice using the pair of threaded Body Clamps (Tool 1). Do not over tighten. (See Fig 1.)
2. Using 2 standard 'C' spanners (Not supplied), lock together a pair of the Air Jacks Mounting Rings supplied with the Air Jack. (See Fig 1.)

Fig 1.



Fig 2.



3. Remove from the vice and fit the Cap Clamp (Tool 2) to the knurled Air Jack Cap. Locate the Air Jack and Cap Clamp vertically, clamping the Cap Clamp in the vice. (See Fig 2.)

4. Using a 'C' spanner, rotate the lower Mounting Ring anti-clockwise to unscrew the Body from the Cap.

Note:- Approximately every $\frac{1}{2}$ turn of the Body, use Pin Tool (Tool 3), located in the Air Jack Foot to rotate the Foot clockwise $\frac{1}{2}$ turn.

This is to prevent the internal Tension Spring being wound up and damaged. Continue for approximately 6 full turns until the Cap thread is fully out of the Body. The internal Tension Spring will keep the 2 parts pulled together. (See Fig 2.)

5. Remove unit from the vice, take off the Cap Tool and re-locate the unit horizontally in the vice again using the Body Clamps (Tool 1). (See Fig 3.)

6. Screw the 'T' Bar (Tool 4) onto the Air Jack Inlet Adaptor thread. Pull on the 'T' Bar to expose approximately 8 coils of the internal Tension Spring and slide the Spring Trap Plate (Tool 5) over 1 spring coil and against the open end of the Body. (See Fig 3.)

7. Remove the 'T' Bar and unhook the Cap from the Tension Spring. Locate Spring Hook Tool (Tool 6) onto the Tension Spring hook, pull gently to



Fig 3.



Fig 4.



Fig 5.

take the spring load and remove the Spring Trap Plate. Carefully release the load to allow the spring fully back inside the Air Jack and remove the Hook Tool.

(See Fig 4.)

8. Remove the unit from the vice and pull on the Foot to expose the Air Jack Ram. Fit the pair of Ram Clamps (Tool 7) to the Ram and tighten securely in the vice but do not over tighten. Then clean the Ram first if it is dirty. Fit Pin Tool (Tool 3) onto the Foot and unscrew the Foot anti-clockwise out of the Ram using either a Torque spanner and a 21mm Socket or using a 15mm diameter Tommy Bar (Not supplied) through the hole in the Pin Tool. Pull the Foot and spring out of the Ram. (See Fig 5.)

9. Remove the Inlet Adaptor from the Cap and discard the copper washers.

10. The Bearing Housing is still located in the Body, but no tool is supplied, as it is not necessary to remove it. The small Bearing in the Bearing housing can be replaced in situ.

11. The Air Jack is now sufficiently dis-assembled to clean, lubricate and fit replacement parts.

AIR JACK SERVICING INSTRUCTIONS AND RE-ASSEMBLY

These notes assume that all metal components are in a re-usable condition. If any component is damaged beyond use, then the Air Jack should either be returned to AP Racing for full re-conditioning, including replacement of the damaged components, or additional replacement parts will need to be ordered.

1. Remove all 3 O-rings from the Cap, the Piston and the Foot and both plastic Bearings and discard them. Thoroughly clean all other metal components. Use an alcohol based cleaning fluid. i.e. Methylated Spirit or warm soapy water. **DO NOT USE ANY PETROLEUM BASED CLEANERS AS THESE WILL DAMAGE THE RUBBER SEALS.**

2. Use the 3 O-rings, the 2 Bearings and the 2 Copper washers contained in Repair Kit CP2985-1RK to replace those parts discarded. In order to install both Bearings, they will need to be split as shown in the illustration included in the repair kit.

3. Apply Silicon Spray lubricant to the main Bore of the Body and pack the Main O-Ring groove of the Piston with Silicon Grease as shown in the illustration below. Take care not to allow lubricant onto any of the threads that are to be bonded with Loctite. (See fig 6.)

4. Re-Assembly is the exact reverse of the operations listed above. Assembly Bullet (Tool 8) is to be engaged in the end of the Ram to aid its re-insertion through the Body and Bearing Housing assembly.

Position O-Ring in this groove, against the face shown. Pack the remainder of the seal groove with silicon grease.

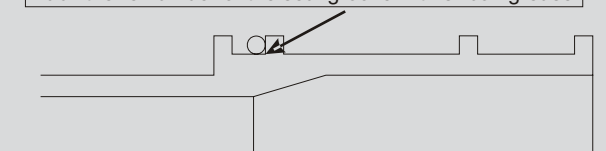
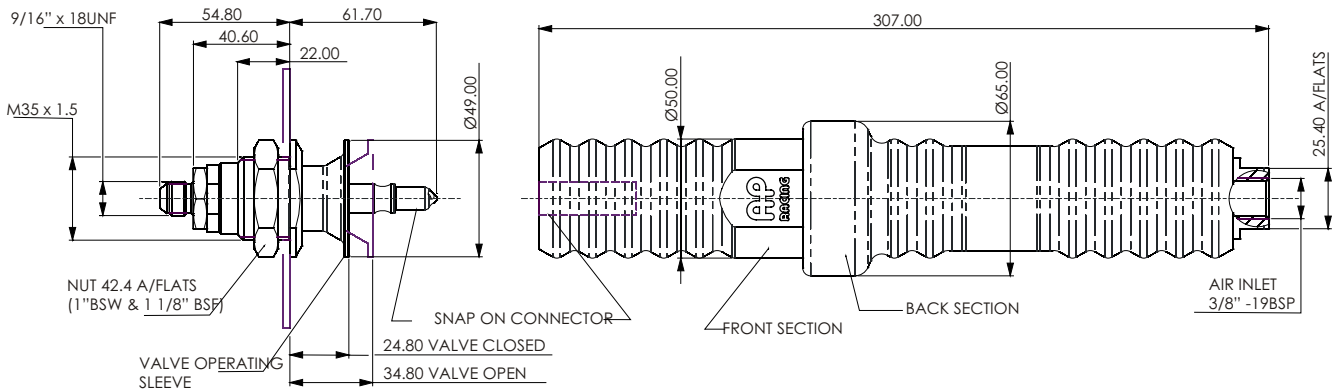

Fig 6.

5. The Foot is to be bonded to the Ram and the Cap is to be bonded into the Body using Loctite 270. Ensure threads are clean, apply Loctite Activator 7649 and then apply 1 complete circumferential ring of Loctite to the first turn only of the Male thread. Do not apply excess Loctite. With the Activator applied, the Loctite will set quickly, so follow the procedure above, only just prior to threading any pair of parts together. Quickly screw parts together until fully seated, ensuring that any O-rings are correctly positioned and are not cut. Using the same tools used for dis-assembly, tighten all parts securely. Use a compressed air supply of 5 Bar maximum to check for leaks.

AIR JACK LANCE AND CONNECTOR

To complement the range of Air Jack, AP Racing have introduced a Lance (CP6006-5) and Connector Valve (CP6006-3). These products are designed to have high flow and positive operation. The connector is lightweight and has a two position valve to release system pressure. The lance is protected by a durable rubber hand grip.



INSTALLATION & OPERATION

INSTALLATION:

1. ATTACH THE CONNECTOR VALVE ASSEMBLY TO VEHICLE AND LINK TO AIR JACKS.
2. ATTACH AIR LINE TO THE LANCE ASSEMBLY.

CONNECTING:

3. WITH THE VALVE IN ITS OPEN POSITION, OFFER THE LANCE ASSEMBLY SQUARELY ONTO THE SNAP ON CONNECTOR OF THE VALVE ASSEMBLY.
4. PUSH THE LANCE INTO PLACE UNTIL IT LATCHES ONTO THE VALVE. THE VALVE WILL CLOSE AUTOMATICALLY. AIR WILL IMMEDIATELY PASS THROUGH THE VALVE INTO THE AIR JACKS

DIS-CONNECTION:

5. HOLD THE BACK SECTION OF THE LANCE STEADY AND PULL THE FRONT SECTION FULLY BACK INTO IT AND THEN PULL THE WHOLE LANCE ASSEMBLY OFF THE VALVE. THE VALVE WILL REMAIN CLOSED AND THE AIR JACKS EXTENDED.

VENTING THE AIR JACKS:

6. OPEN THE VALVE BY PULLING THE OPERATING SLEEVE FULLY OUT.

SAFETY PROPS.

CP2985 TYPE.



These one piece cast aluminium safety devices have been designed to be clipped around the ram of the air jack when fully extended to prevent accidental withdrawal of the ram. The air jack safety prop has an integral cast handle and an epoxy coating finish for durability. (Safety Props must be ordered separately).

- CP2985-14. for use with CP2985 -1 & CP2995-1.
- CP2985-17. for use with CP2985-15 & -CP2985-29.

CP3985 TYPE.



These one piece machined from billet aluminium safety devices have been designed to be clipped around the ram of the air jack when fully extended to prevent accidental withdrawal of the ram. The air jack safety prop has an integral billet handle (where specified) and an anodised surface finish for durability. (Safety Props must be ordered separately)

- CP3985-31 for use with CP3985-310EV (Handle provided).
- CP3985-23 for use with CP3985-230EV (Handle provided).
- CP3985-19 for use with CP3985-190EV (Handle provided).
- CP3985-15 for use with CP3985-150EV (Handle not provided).
- CP3985-13 for use with CP3985-130EV (Handle not provided).

EXHAUST VALVE.

CP2985, CP2995 Air Jacks can be supplied with the Exhaust Valve fitted, or the Exhaust Valve can be supplied in a kit form (CP2985-7) which can be fitted by the customer. CP2985-7 kit is supplied as a single exhaust valve with two rubber seals and a pressure sealing ring for fitting to all AP Racing Air Jacks. Care should be taken so that the rubber seals are located correctly in the pressure sealing ring when the exhaust valve is screwed down on the male adaptor on top of the Air Jack.

The Exhaust Valve should be positioned so that the outlet face is not obstructed and also that the pressure flow of air does not damage anything within the car.

